

1

2

3

4

NOTES:

- (1) PURGE ALL WATER SUPPLY LINES TO REMOVE SOLIDS PRIOR TO TOY INSTALLATION.
- (2) PROVIDE ELECTRICAL BOND WITH POOL REBAR.
- (3) INSTALL ALL WATER TOYS PLUMB AND LEVEL.
- (4) PROVIDE STRAINER UPSTREAM OF TOY WITH MAX 1/32" (0.8mm) PERFORATIONS.

A

A

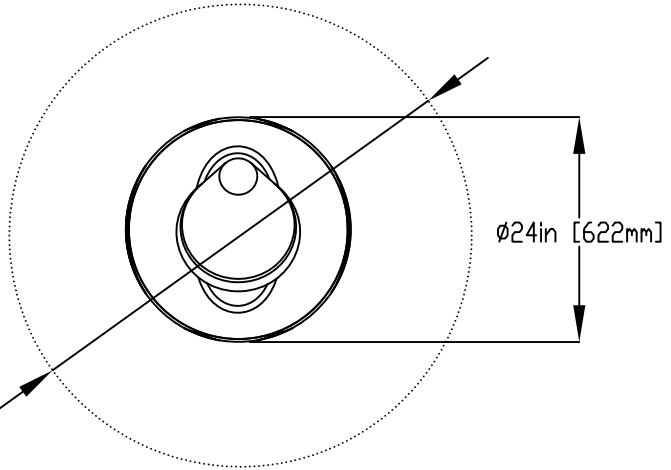

B

B

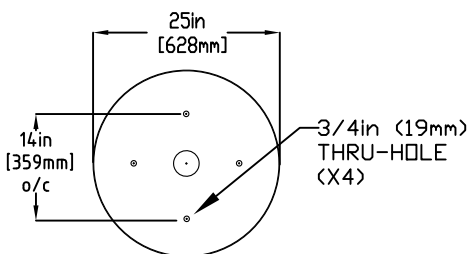

MOUNTING PLATE DETAIL

C

C

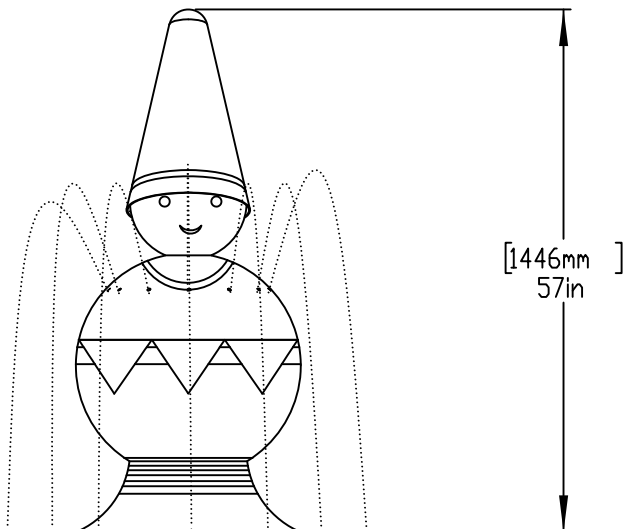

D

D

- 1. BOLT UNIT WITH MOUNTING PLATE
- 2. MAKE PLUMBING CONNECTIONS
- 3. LOWER UPPER TOY AND ATTACH TO UNIT

1/2" (13mm) X 8" (203mm) 316SS THREADED ROD, C/W FENDER WASHER, LOCK WASHER & NUT (X4) MINIMUM 6" (152mm) EMBEDMENT, EPOXY SET ANCHOR ADHESIVE TO BE PROVIDED BY CONTRACTOR

1" (25mm) FLEX HOSE PROVIDED BY EMPEX

2" (50mm) COUPLING
2" (50mm) TO 1" (25mm) REDUCER
1" (25mm) HOSE BARB W/SS CLAMP TO BE PROVIDED BY CONTRACTOR

E

E

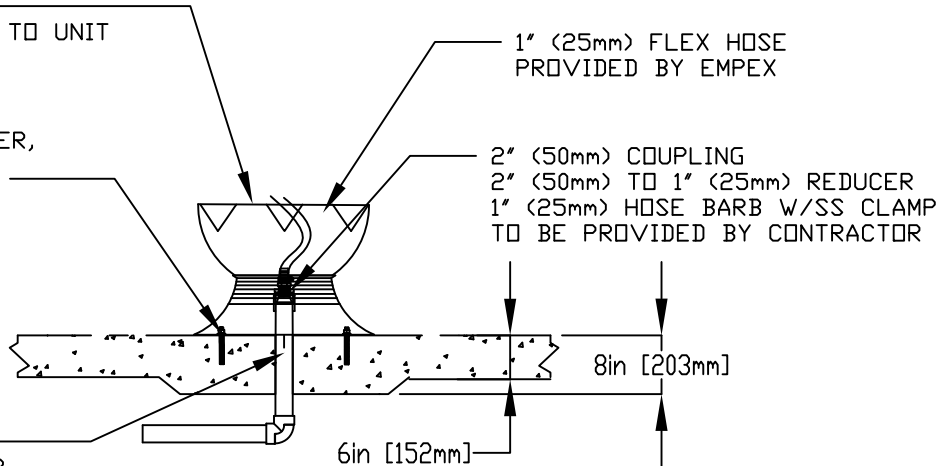

WATERFEED
2" (50mm) PVC SCH 40 PIPE
EXTENDED 6" (152mm) ABOVE SLAB.

8in [203mm]

6in [152mm]

F

F



Notes: Overall dimensions of toys are approximate.

© EMPEX WATERTOYS

WATER SUPPLY
30 gpm @ 25 psi
1.89L/S @17.5m

AQUAELF

AN106

27/04/2023

SCALE:

Sheet 1 of 1

1

2

3

4