

NOTES:

(1) PURGE ALL WATER SUPPLY LINES TO REMOVE SOLIDS PRIOR TO TOY INSTALLATION.

(2) PROVIDE ELECTRICAL BOND WITH POOL REBAR.

(3) INSTALL ALL WATER TOYS PLUMB AND LEVEL.

(4) PROVIDE STRAINER UPSTREAM OF TOY WITH MAX 1/32" (0.8mm) PERFORATIONS.

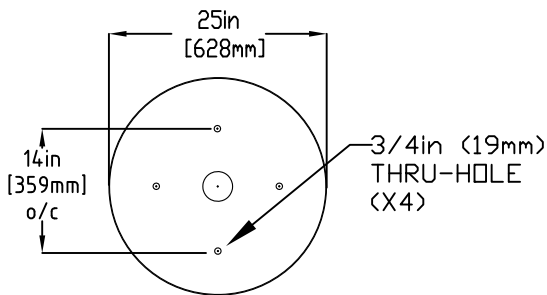
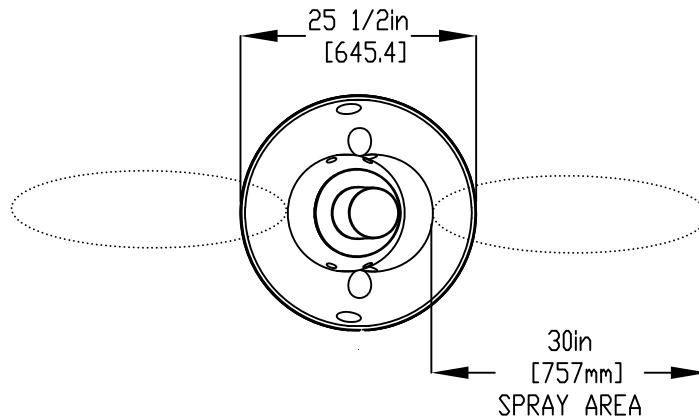

MOUNTING PLATE DETAIL

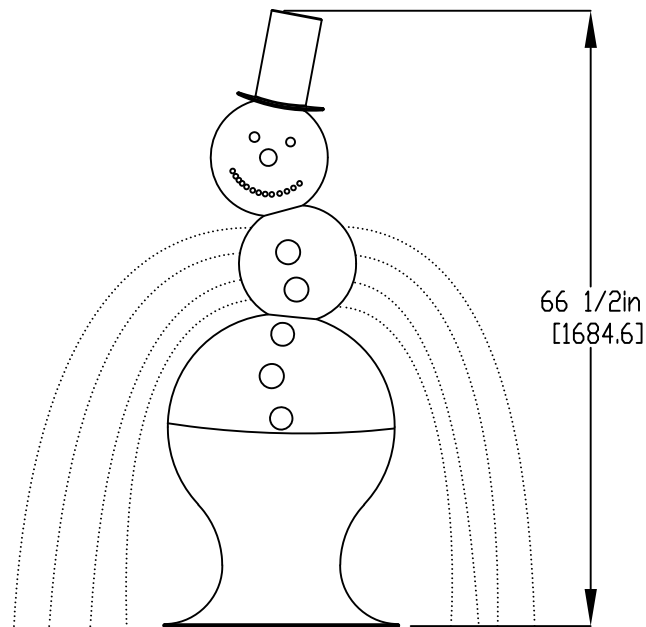

- 1. BOLT BASE WITH MOUNTING PLATE
- 2. MAKE PLUMBING CONNECTIONS
- 3. LOWER TOY AND ATTACH TO BASE

5/8" (16mm) X 9" (229mm) 316 SS  
 THREADED ROD, C/W FENDER WASHER  
 LOCK WASHER & NUT (X4) MINIMUM  
 6" EMBEDMENT, EPOXY SET  
 ANCHOR ADHESIVE (EACH LEG)  
 TO BE PROVIDED BY CONTRACTOR

1" (25mm) FLEX HOSE  
 PROVIDED BY EMPEX

2" (50mm) COUPLING  
 2" (50mm) TO 1" (25mm) REDUCER  
 1" (25mm) HOSE BARB W/SS CLAMP  
 TO BE PROVIDED BY CONTRACTOR

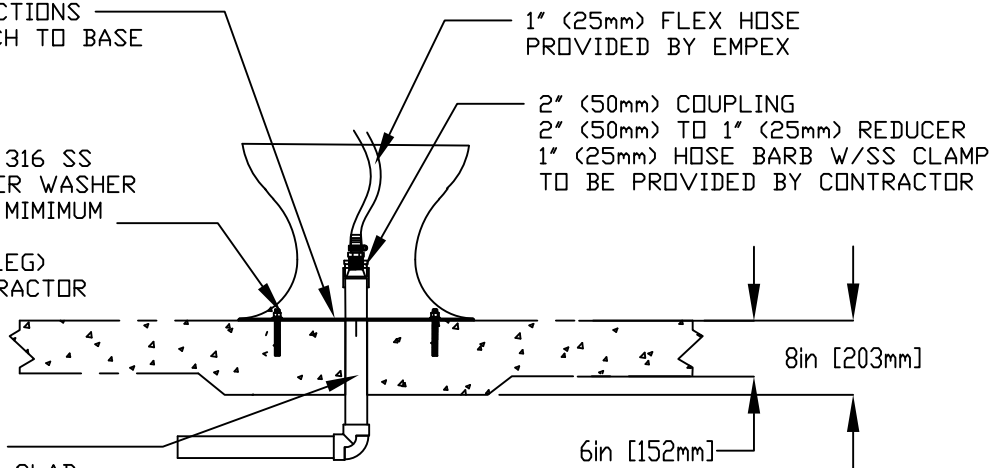

WATERFEED  
 2" (50mm) PVC SCH 40 PIPE  
 EXTENDED 6" (152mm) ABOVE SLAB.

Notes: Overall dimensions of toys are approximate.

© EMPEX WATERTOYS



WATER SUPPLY

30 gpm @ 25 psi  
 1.89L/S @17.5m

AQUASNOW

AN109

01/05/2023

SCALE:

Sheet 1 of 1