

NOTES:

- (1) PURGE ALL WATER SUPPLY LINES TO REMOVE SOLIDS PRIOR TO TOY INSTALLATION.
- (2) PROVIDE ELECTRICAL BOND WITH POOL REBAR.
- (3) INSTALL ALL WATER TOYS PLUMB AND LEVEL.
- (4) PROVIDE STRAINER UPSTREAM OF TOY WITH MAX 1/32" (0.8mm) PERFORATIONS.

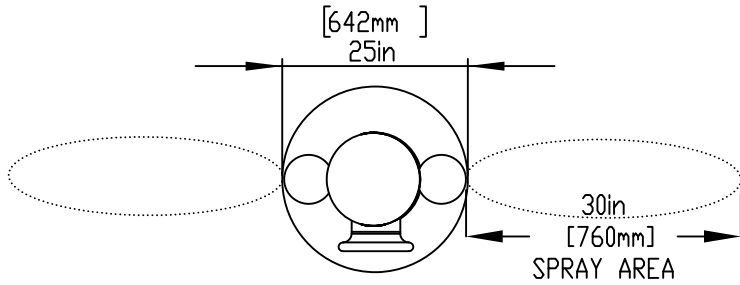

2-WAY DIVERTER

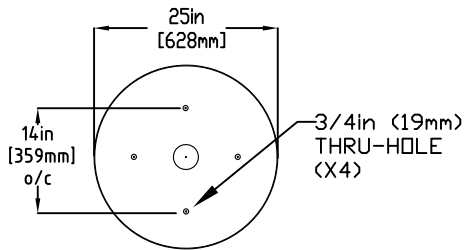

MOUNTING PLATE DETAIL

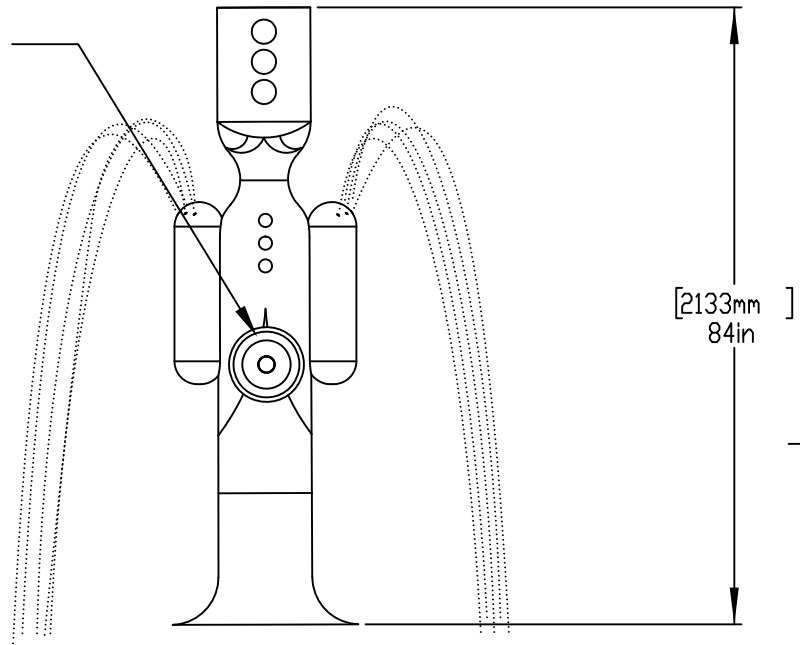

- 1. BOLT BASE WITH MOUNTING PLATE
- 2. MAKE PLUMBING CONNECTIONS
- 3. LOWER TOY AND ATTACH TO BASE

1/2" (13mm) X 8" (203mm) 316SS THREADED ROD, C/W FENDER WASHER, LOCK WASHER & NUT (X4) MINIMUM 6" (152mm) EMBEDMENT, EPOXY SET ANCHOR ADHESIVE TO BE PROVIDED BY CONTRACTOR

1" (25mm) FLEX HOSE PROVIDED BY EMPEX

2" (50mm) COUPLING
2" (50mm) TO 1" (25mm) REDUCER
1" (25mm) HOSE BARB W/SS CLAMP TO BE PROVIDED BY CONTRACTOR

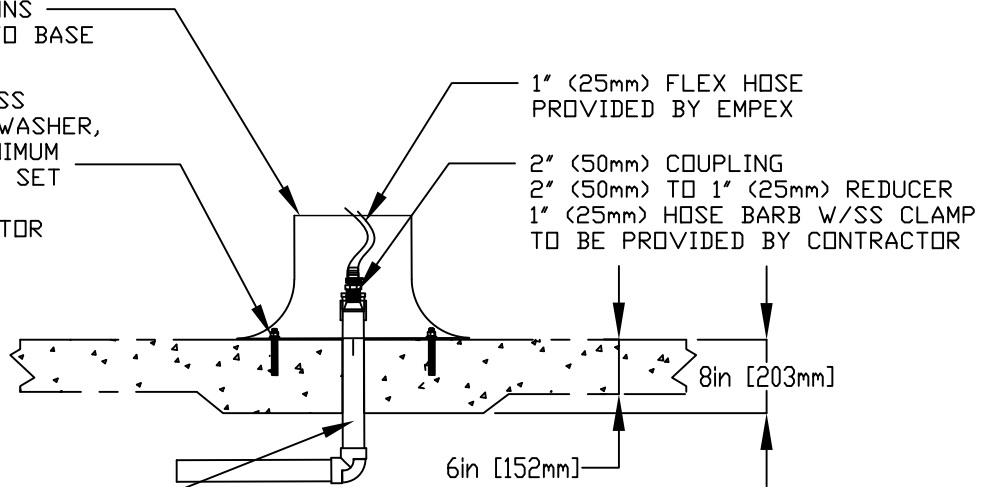

WATERFEED
2" (50mm) PVC SCH 40 PIPE EXTENDED 6" (152mm) ABOVE SLAB.

Notes: Overall dimensions of toys are approximate.

© EMPEX WATERTOYS



WATER SUPPLY
30 gpm @ 25 psi
1.89L/S @17.5m

AQUANUT

AN111

6/6/2018

SCALE:

Sheet 1 of 1