

NOTES:

(1) PROVIDE ELECTRICAL BOND WITH POOL REBAR.

(2) 2 PART EPOXY MAY BE USED IN LIEU OF INSERT ANCHOR.

(3) PURGE ALL WATER SUPPLY LINES TO REMOVE SOLIDS PRIOR TO TOY INSTALLATION.

(4) INSTALL ALL WATER TOYS PLUMB AND LEVEL.

(5) PROVIDE STRAINER UPSTREAM OF TOY WITH MAX 1#32" (0.8mm) PERFORATIONS.

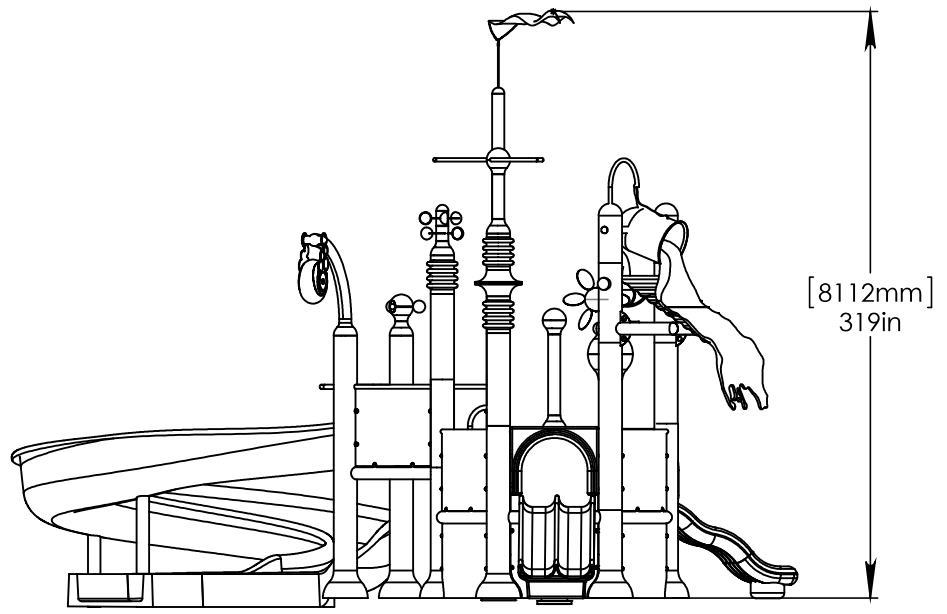
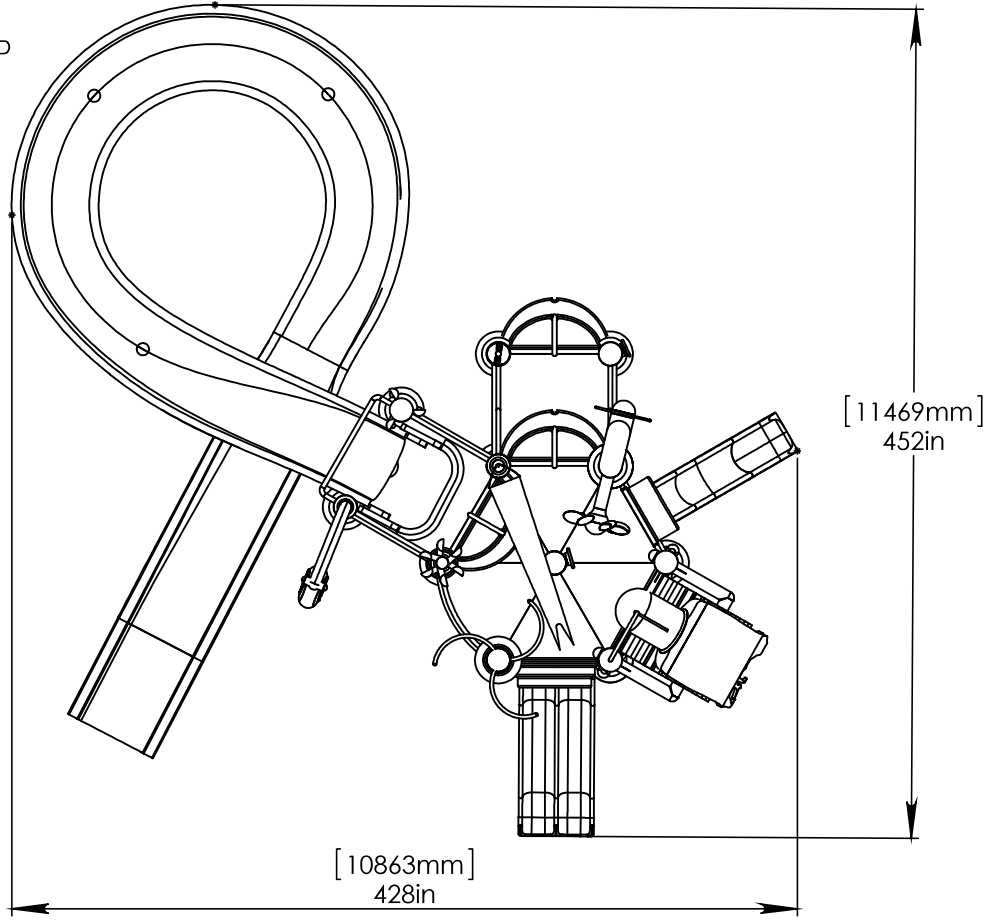

Notes : (1) Dual Dimensions  
 (2) Outer dimensions of toys are approximate.

© EMPEX WATER TOYS  
 JAN 23, 2014

Scale  
 N.T.S.

WATER SUPPLY  
 600 gpm @ 20 psi  
 38L/S @14m

# C610-CR-1S AQUADEK

Edition  
 Sheet  
 1/1