

NOTES:

- (1) PURGE ALL WATER SUPPLY LINES TO REMOVE SOLIDS PRIOR TO TOY INSTALLATION.
- (2) PROVIDE ELECTRICAL BOND WITH POOL REBAR.
- (3) INSTALL ALL WATER TOYS PLUMB AND LEVEL.
- (4) PROVIDE STRAINER UPSTREAM OF TOY WITH MAX 1/32" (0.8mm) PERFORATIONS.

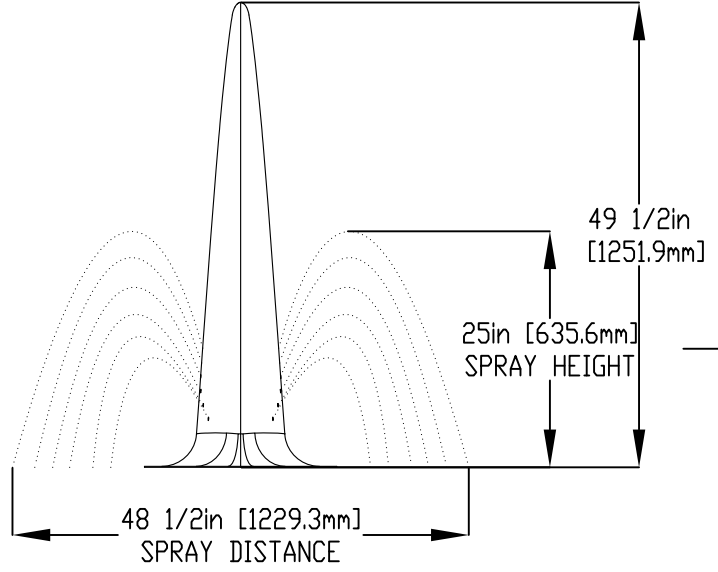
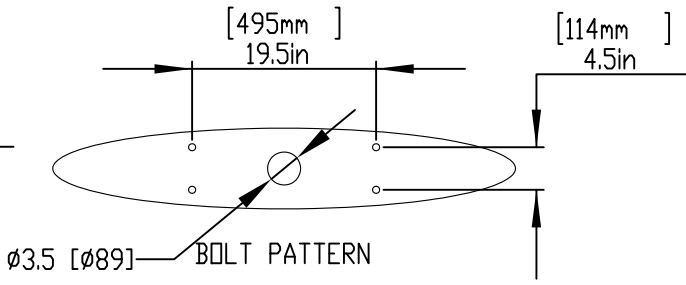
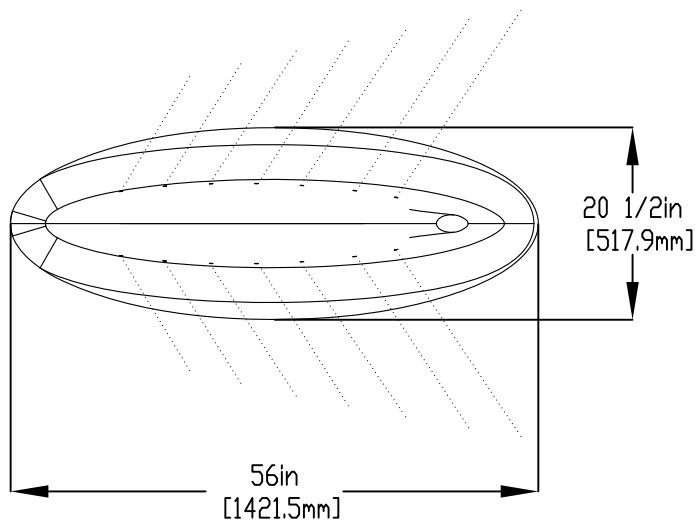

- 1. Bolt insert sleeve
- 2. Make Plumbing connection
- 3. Lower Toy & Bolt to Insert

5/8" (16mm) X 9" (229mm) 316 SS THREADED ROD, C/W FENDER WASHER LOCK WASHER & NUT (X4) MINIMUM 6" EMBEDMENT, EPOXY SET ANCHOR ADHESIVE TO BE PROVIDED BY CONTRACTOR

1-1/2" (38mm) FLEX HOSE PROVIDED BY EMPEX

2" (50mm) COUPLING
2" (50mm) TO 1-1/2" (38mm REDUCER)
1-1/2" (38mm) HOSEBARB W/SS CLAMP TO BE PROVIDED BY CONTRACTOR

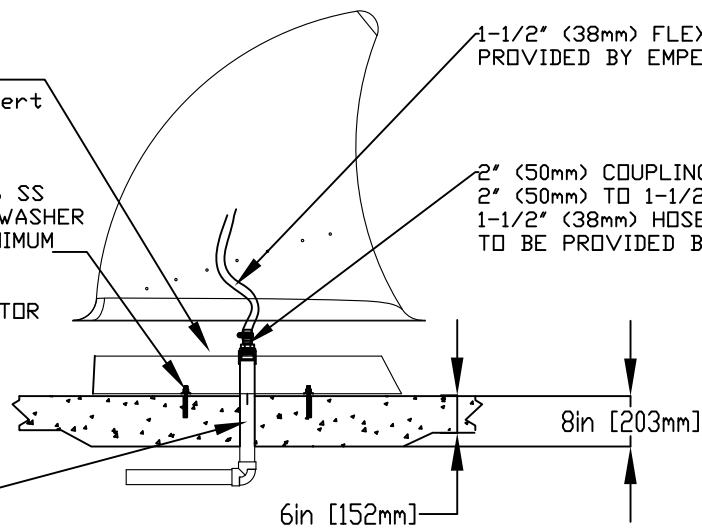

Notes: Overall dimensions of toys are approximate.

© EMPEX WATERTOYS

WATER SUPPLY
30 gpm @ 25 psi
1.89L/S @17.5m

AQUAFIN

M503

10/30/2015

SCALE:

Sheet 1 of 1