

1

2

3

4

NOTES:

- (1) PURGE ALL WATER SUPPLY LINES TO REMOVE SOLIDS PRIOR TO TOY INSTALLATION.
- (2) PROVIDE ELECTRICAL BOND WITH POOL REBAR.
- (3) INSTALL ALL WATER TOYS PLUMB AND LEVEL.
- (4) PROVIDE STRAINER UPSTREAM OF TOY WITH MAX 1/32" (0.8mm) PERFORATIONS.

Ø120in  
[Ø3048.0mm]  
SPRAY DIAMETER

Ø24 1/2in  
[622.3mm]

71in  
[1804.9mm]

109in  
[2771.1mm]

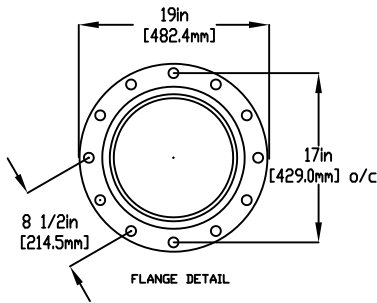

LOWER FLANGE  
COVERS AFTER TOY  
IS INSTALLED

1/2" (13mm) X 8" (203mm) 316SS  
THREADED ROD, C/W FENDER WASHER,  
LOCK WASHER & NUT (X6) MINIMUM  
6" (152mm) EMBEDMENT, EPOXY SET  
ANCHOR ADHESIVE  
TO BE PROVIDED BY CONTRACTOR

1" (25mm) FLEX HOSE  
PROVIDED BY EMPEX

2" (50mm) COUPLING  
2" (50mm) TO 1" (25mm) REDUCER  
1" (25mm) HOSE BARB W/SS CLAMP  
TO BE PROVIDED BY CONTRACTOR

WATERFEED  
2" (50mm) PVC SCH 40 PIPE  
EXTENDED 6" (152mm) ABOVE SLAB.

8in [203mm]  
6in [152mm]

Notes: Overall dimensions of toys are approximate.  
Approximate Weight: 174lbs / 79.1kgs

© EMPEX WATERTOYS



WATER SUPPLY

30 gpm @ 25 psi  
1.89 L/S @17.5m

AQUABOIA

Z207

01/06/2023

SCALE:

Sheet  
1 of 1

1

2

3

4