

1

2

3

4

NOTES:

- (1) PURGE ALL WATER SUPPLY LINES TO REMOVE SOLIDS PRIOR TO TOY INSTALLATION.
- (2) PROVIDE ELECTRICAL BOND WITH POOL REBAR.
- (3) INSTALL ALL WATER TOYS PLUMB AND LEVEL.
- (4) PROVIDE STRAINER UPSTREAM OF TOY WITH MAX 1/32" (0.8mm) PERFORATIONS.

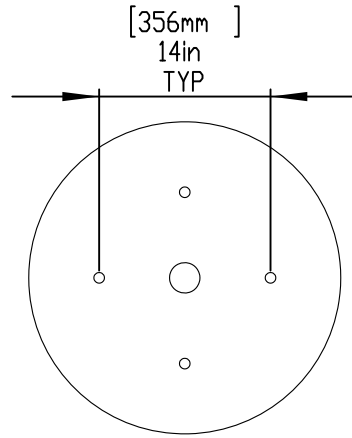

ANCHOR PATTERN

120in [3048mm] SPRAY DIAMETER NTS

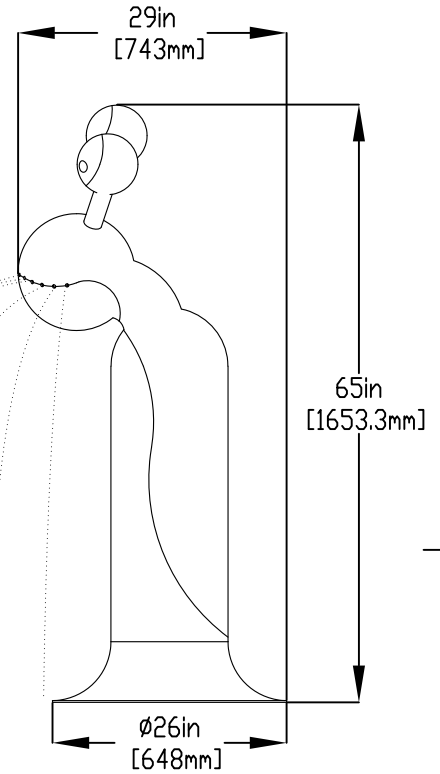
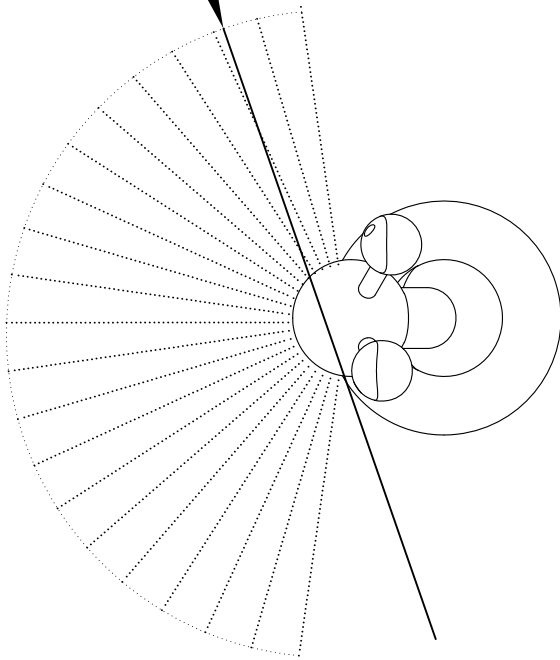

LOWER TOY ONCE BASE IS ANCHORED TO THE GROUND.

1/2" (13mm) X 8" (203mm) 316SS THREADED ROD, C/W FENDER WASHER LOCKWASHER & NUT (X4) EPOXY SET ANCHOR ADHESIVE TO BE PROVIDED BY CONTRACTOR

1" (25mm) FLEX HOSE PROVIDED BY EMPEX.

2" (50mm) COUPLING  
2" (50mm) - 1" (25mm) REDUCER  
1" (25mm) HOSEBARB W/SS CLAMP TO BE PROVIDED BY CONTRACTOR

WATERFEED  
2" (50mm) PVC SCH 40 PIPE EXTENDED 6" (152mm) ABOVE SLAB

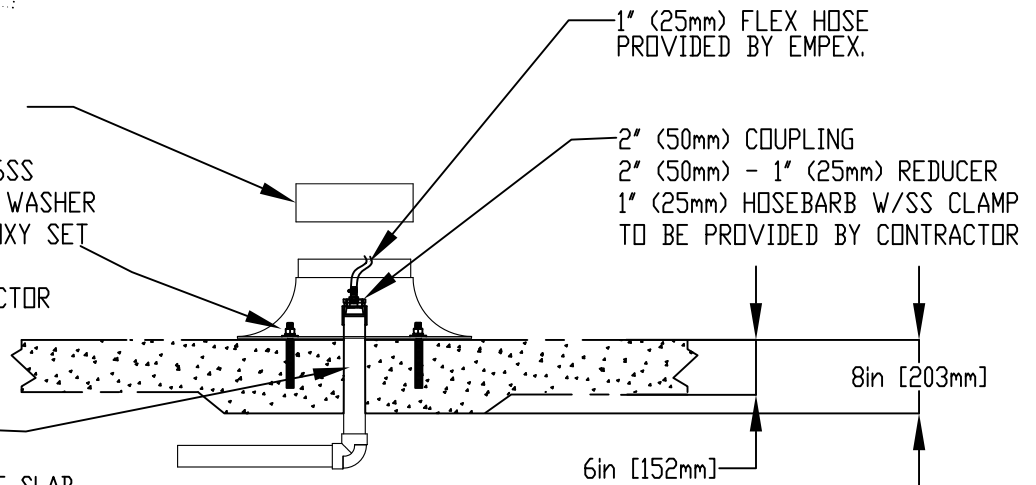

Notes: Overall dimensions of toys are approximate.

© EMPEX WATERTOYS

WATER SUPPLY  
30 gpm @ 25 psi  
1.89L/S @17.5m

AQUAHOPPER

TR273S

18/11/2022

SCALE:

Sheet  
1 of 1

1

2

3

4