

1

2

3

4

NOTES:

- (1) PURGE ALL WATER SUPPLY LINES TO REMOVE SOLIDS PRIOR TO TOY INSTALLATION.
- (2) PROVIDE ELECTRICAL BOND WITH POOL REBAR.
- (3) INSTALL ALL WATER TOYS PLUMB AND LEVEL.
- (4) PROVIDE STRAINER UPSTREAM OF TOY WITH MAX 1/32" (0.8mm) PERFORATIONS.

ø84in [2133.6mm]
SPRAY DIAMETER

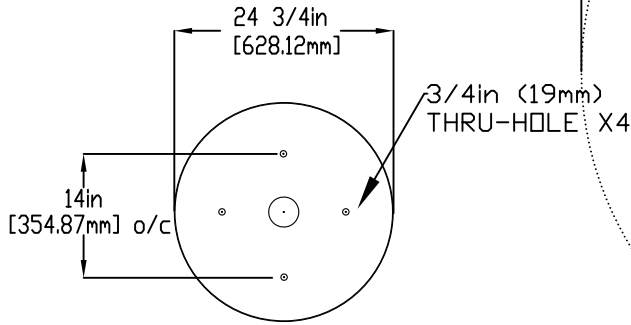
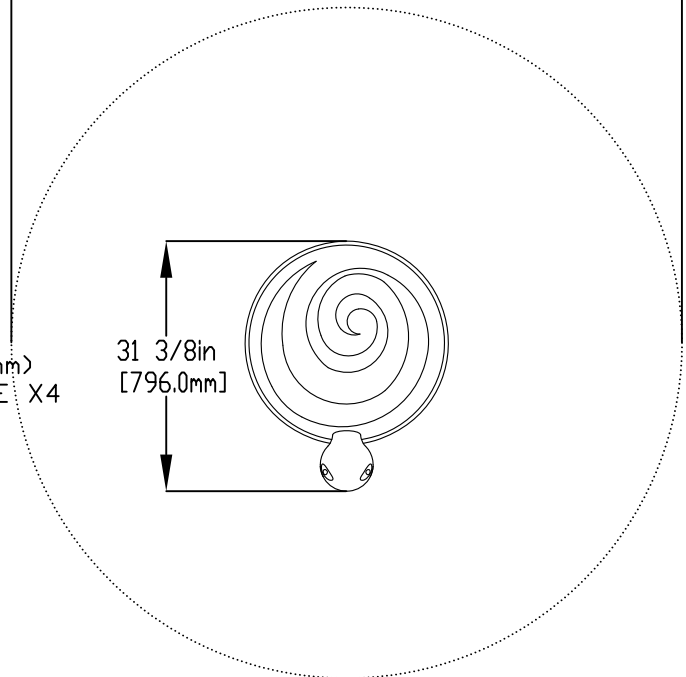

MOUNTING PLATE DETAIL

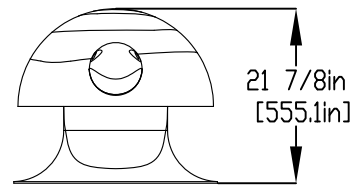
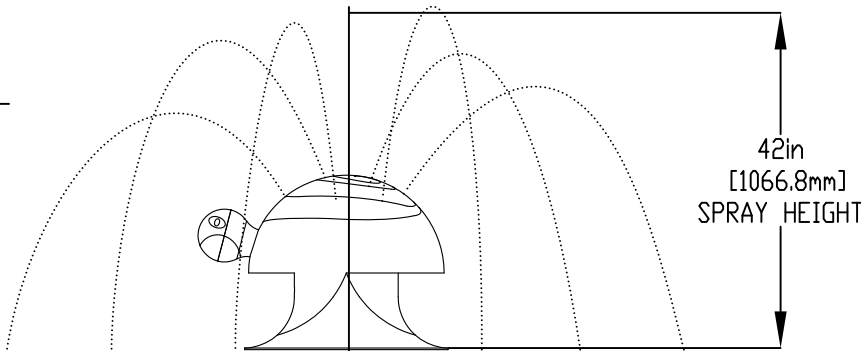

- 1. BOLT BASE
- 2. MAKE PLUMBING CONNECTION
- 3. LOWER TOY & BOLT TO BASE

1/2" (13mm) X 8" (203mm) 316SS
THREADED ROD C/W FENDER WASHER,
LOCK WASHER & NUT (X4). MINIMUM
6" (152mm) EMBEDMENT. EPOXY SET
ANCHOR ADHESIVE
TO BE PROVIDED BY CONTRACTOR

1" (25mm) FLEX HOSE
PROVIDED BY EMPEX

2" (50mm) COUPLING
2" (50mm) TO 1" (25mm) REDUCER
1" (25mm) HOSE BARB W/SS CLAMP
TO BE PROVIDED BY CONTRACTOR

WATER FEED
2" (50mm) PVC SCH 40 PIPE
EXTENDED 6" (152mm) ABOVE SLAB

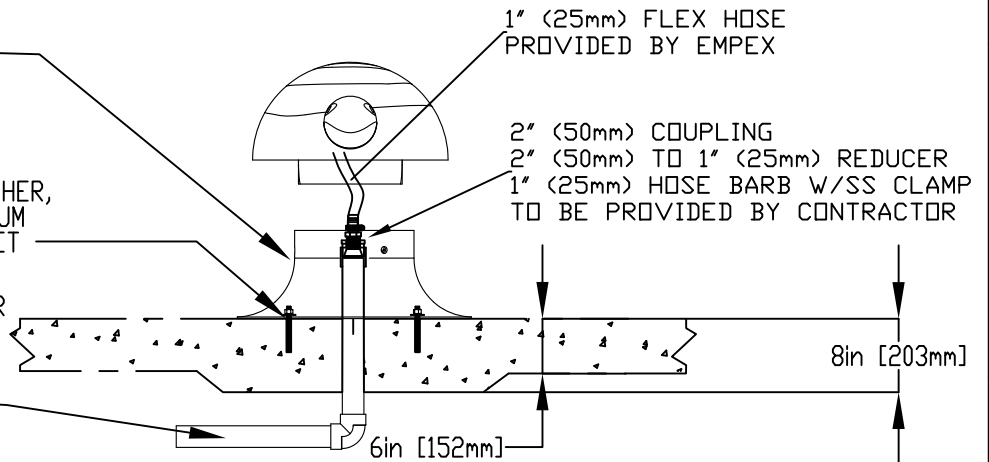

Notes: Overall dimensions of toys are approximate.
Approximate Weight: 42lbs / 19.1kgs

© EMPEX WATERTOYS

WATER SUPPLY

20 gpm @ 25 psi
1.26 L/S @17.5m

AQUATORT

Z204

11/06/2020

SCALE:

Sheet
1 of 1

1

2

3

4