

NOTES:

- (1) PURGE ALL WATER SUPPLY LINES TO REMOVE SOLIDS PRIOR TO TOY INSTALLATION.
- (2) PROVIDE ELECTRICAL BOND WITH POOL REBAR.
- (3) INSTALL ALL WATER TOYS PLUMB AND LEVEL.
- (4) PROVIDE STRAINER UPSTREAM OF TOY WITH MAX 1/32" (0.8mm) PERFORATIONS.

24in - 36in
[610mm - 914mm]
SPRAY HEIGHT NTS

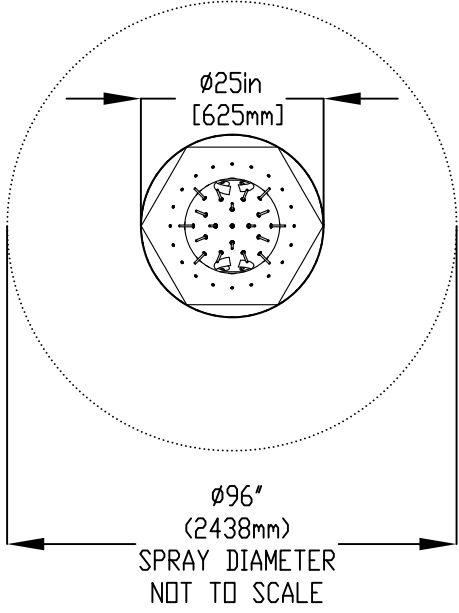

3-WAY
DIVERTER

87 1/2in
[2221.3mm]

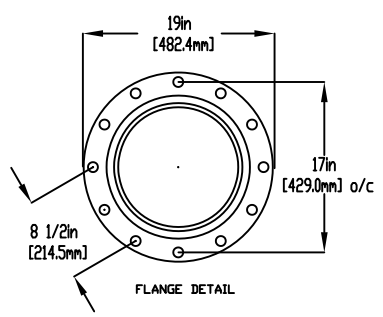

LOWER FLANGE
COVERS AFTER TOY
IS INSTALLED

5/8" (16mm) X 9" (229mm) 316 SS
THREADED ROD, C/W FENDER WASHER
LOCK WASHER & NUT (X6) MINIMUM
6" EMBEDMENT, EPOXY SET
ANCHOR ADHESIVE (EACH LEG)
TO BE PROVIDED BY CONTRACTOR

2" (50mm) FLEX HOSE
PROVIDED BY EMPEX

2" (50mm) COUPLING
2" (50mm) HOSE BARB W/SS CLAMP
TO BE PROVIDED BY CONTRACTOR

WATERFEED
2" (50mm) PVC SCH 40 PIPE
EXTENDED 6" (152mm) ABOVE SLAB.

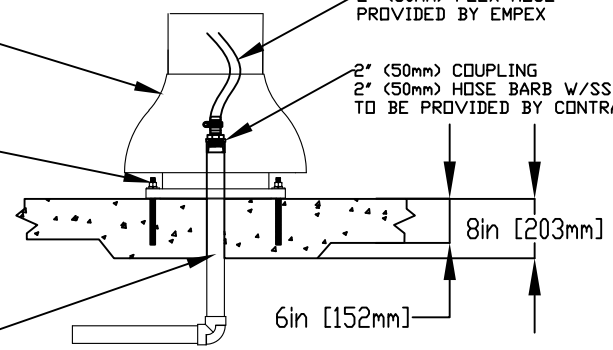

Notes: Overall dimensions of toys are approximate.

© EMPEX WATERTOYS

WATER SUPPLY
30 gpm @ 25 psi
1.89L/S @17.5m

AQUACLUNE

CL301

11/4/2014

SCALE:

Sheet
1 of 1