

1

2

3

4

NOTES:

- (1) PURGE ALL WATER SUPPLY LINES TO REMOVE SOLIDS PRIOR TO TOY INSTALLATION.
- (2) PROVIDE ELECTRICAL BOND WITH POOL REBAR.
- (3) INSTALL ALL WATER TOYS PLUMB AND LEVEL.
- (4) PROVIDE STRAINER UPSTREAM OF TOY WITH MAX 1/32" (0.08mm) PERFORATIONS.

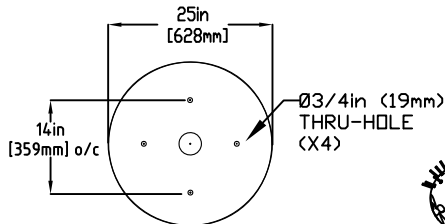
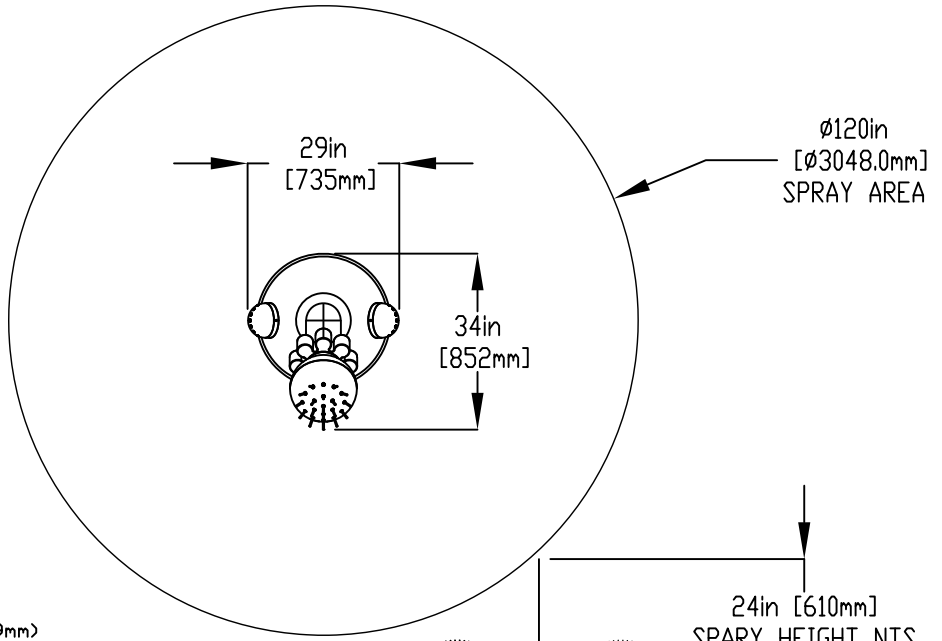

MOUNTING BOLT PATTERN

2-WAY DIVERTER TOP / SIDES

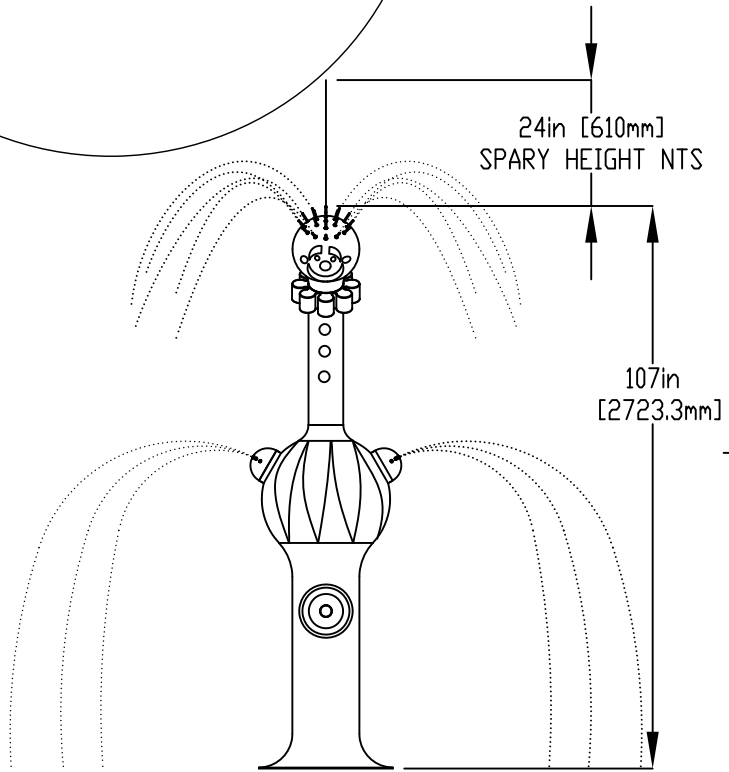
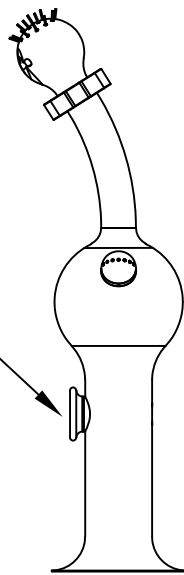

- 1. Bolt insert sleeve
- 2. Make Plumbing connection
- 3. Lower Toy & Bolt to Insert

5/8" (16mm) X 9" (229mm) 316 SS  
 THREADED ROD, C/W FENDER WASHER  
 LOCK WASHER & NUT (X4) MINIMUM  
 6" EMBEDMENT, EPOXY SET  
 ANCHOR ADHESIVE  
 TO BE PROVIDED BY CONTRACTOR

1" (25mm) FLEX HOSE PROVIDED BY EMPEX

2" (50mm) COUPLING  
 2" (50mm) TO 1" (25mm) REDUCER  
 1" (25mm) HOSE BARB W/SS CLAMP  
 TO BE PROVIDED BY CONTRACTOR

WATERFEED  
 2" (50mm) PVC SCH 40 PIPE  
 EXTENDED 6" (152mm) ABOVE SLAB.

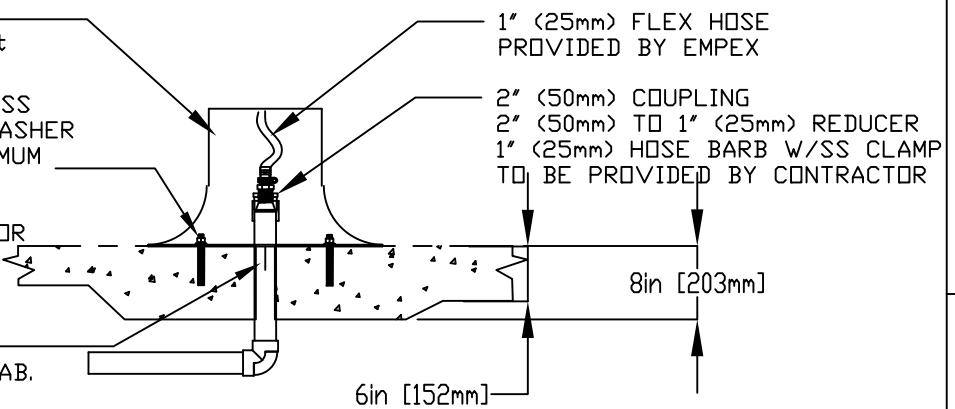

A

A

B

B

C

C

D

D

E

E

F

F



Notes: Overall dimensions of toys are approximate.

© EMPEX WATERTOYS

WATER SUPPLY

30 gpm @ 25 psi  
 1.89L/S @17.5m

AQUACLUNE

CL303

2/9/2023

SCALE:

Sheet 1 of 1

1

2

3

4