

1

2

3

4

NOTES:

(1) PURGE ALL WATER SUPPLY LINES TO REMOVE SOLIDS PRIOR TO TOY INSTALLATION.

(2) PROVIDE ELECTRICAL BOND WITH POOL REBAR.

(3) INSTALL ALL WATER TOYS PLUMB AND LEVEL.

(4) PROVIDE STRAINER UPSTREAM OF TOY WITH MAX 1/32" (0.8mm) PERFORATIONS.

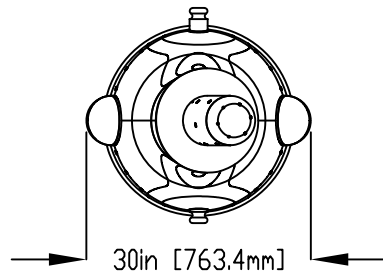

A

A

B

B

C

C

D

D

E

E

F

F

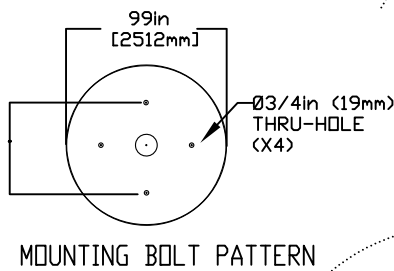

MOUNTING BOLT PATTERN

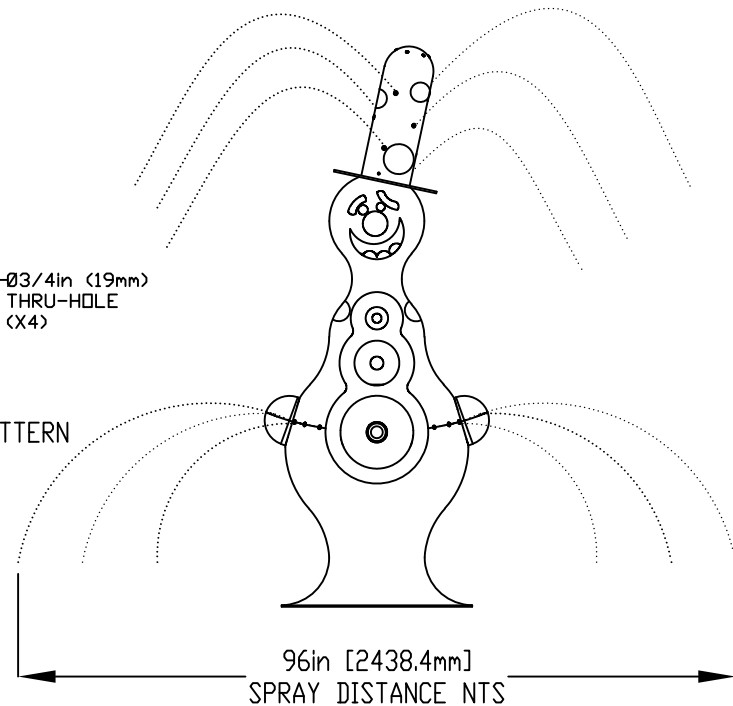

96in [2438.4mm] SPRAY DISTANCE NTS

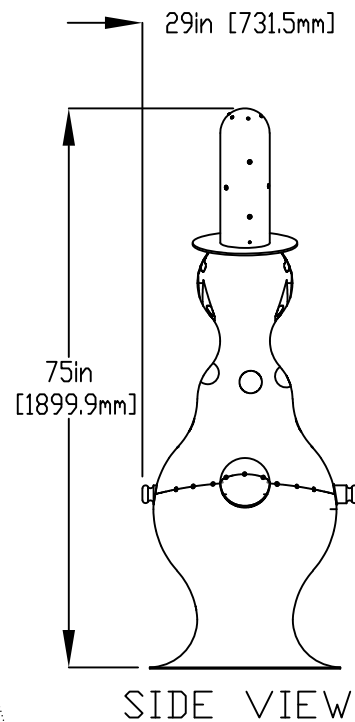

SIDE VIEW

- 1. Bolt insert sleeve
  - 2. Make Plumbing connection
  - 3. Lower Toy & Bolt to Insert
- 5/8" (16mm) X 9' (229mm) 316 SS THREADED ROD, C/W FENDER WASHER LOCK WASHER & NUT (X6) MINIMUM 6" EMBEDMENT, EPOXY SET ANCHOR ADHESIVE (EACH LEG) TO BE PROVIDED BY CONTRACTOR

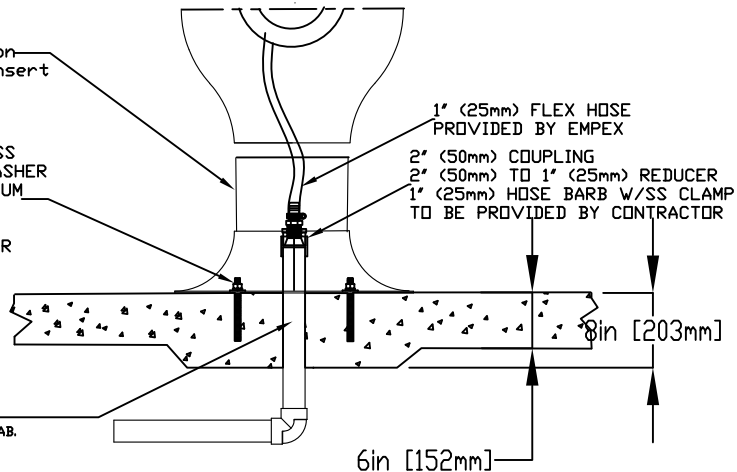

WATERFEED 2' (50mm) PVC SCH 40 PIPE EXTENDED 6' (152mm) ABOVE SLAB.



Notes: Overall dimensions of toys are approximate.

© EMPEX WATERTOYS

WATER SUPPLY

30 gpm @ 25 psi  
1.89L/S @17.5m

AQUACLUNE

CL304

2/9/2023

SCALE:

Sheet 1 of 1

1

2

3

4