

NOTES:

- (1) PURGE ALL WATER SUPPLY LINES TO REMOVE SOLIDS PRIOR TO TOY INSTALLATION.
- (2) PROVIDE ELECTRICAL BOND WITH POOL REBAR.
- (3) INSTALL ALL WATER TOYS PLUMB AND LEVEL.
- (4) PROVIDE STRAINER UPSTREAM OF TOY WITH MAX 1/32" (0.8mm) PERFORATIONS.

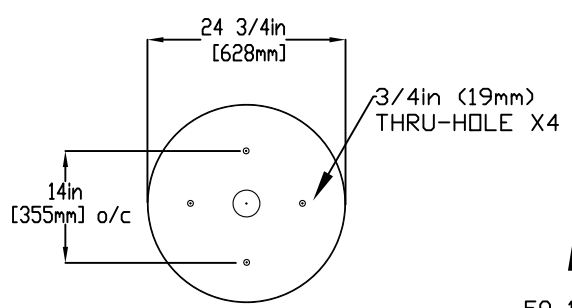

MOUNTING PLATE DETAIL

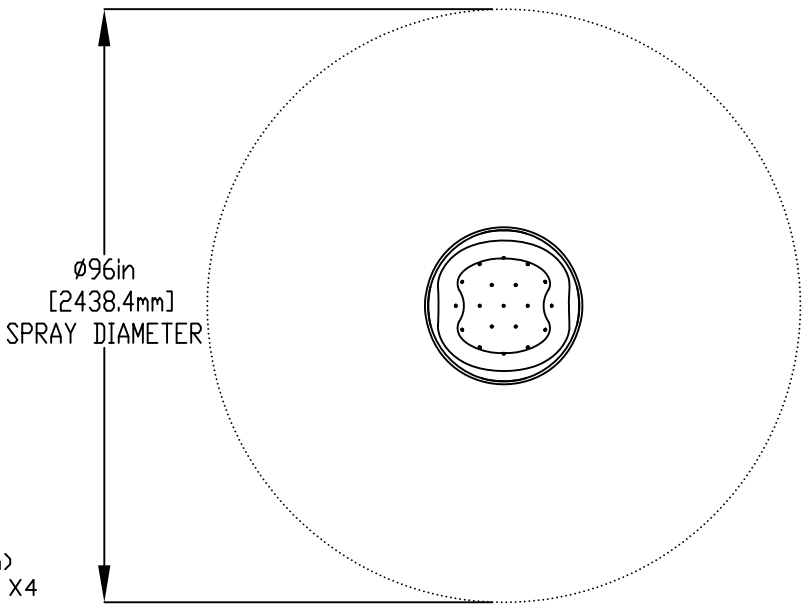
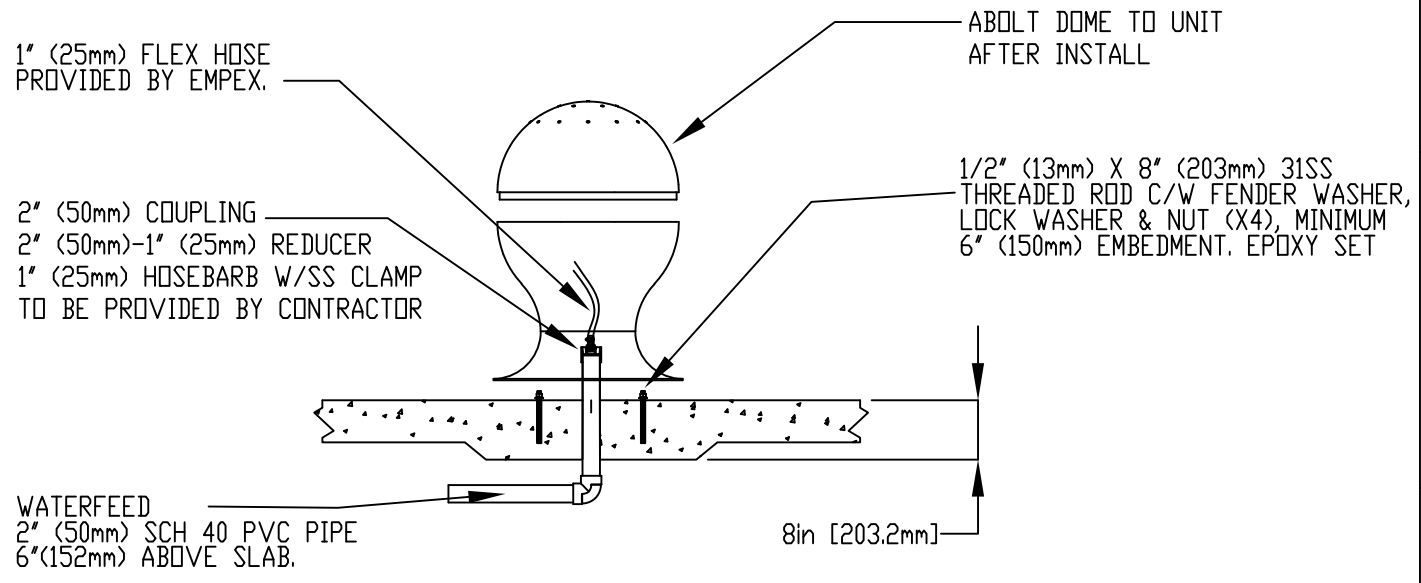
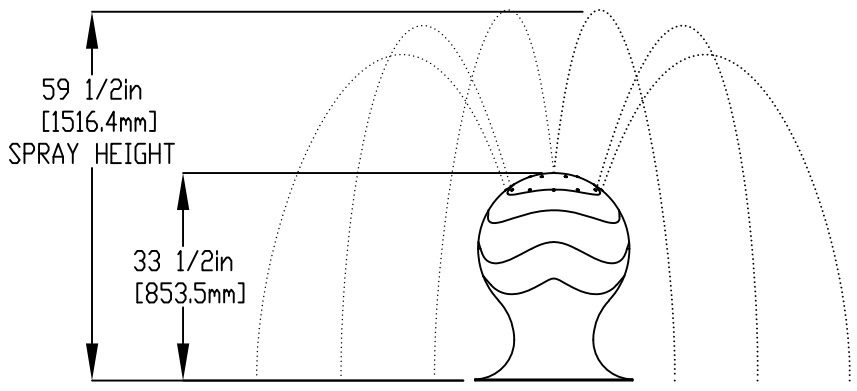

Notes: Overall dimensions of toys are approximate.
Approximate Weight: 42lbs / 19.1kgs

© EMPEX WATERTOYS



WATER SUPPLY
30 gpm @ 25 psi
1.89L/S @17.5m

AQUASPHERE DOLCE

AD807

09/02/2022

SCALE:

Sheet
1 of 1