

1

2

3

4

NOTES:

- (1) PURGE ALL WATER SUPPLY LINES TO REMOVE SOLIDS PRIOR TO TOY INSTALLATION.
- (2) PROVIDE ELECTRICAL BOND WITH POOL REBAR.
- (3) INSTALL ALL WATER TOYS PLUMB AND LEVEL.
- (4) PROVIDE STRAINER UPSTREAM OF TOY WITH MAX 1/32" (0.8mm) PERFORATIONS.

A

A

ø60in [1524.0mm] SPRAY DIAMETER

30 1/2in [777.9mm]

81 1/2in [2067.4mm]

B

B

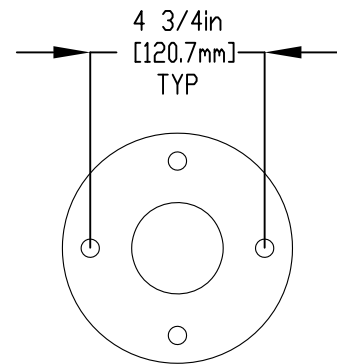
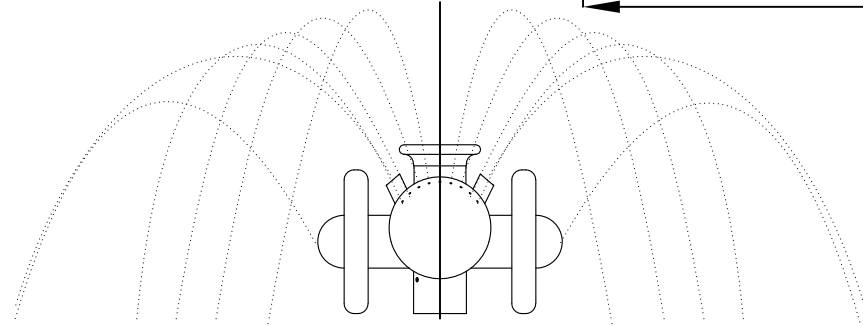

FLANGE DETAIL

C

C

2-WAY DIVERTER

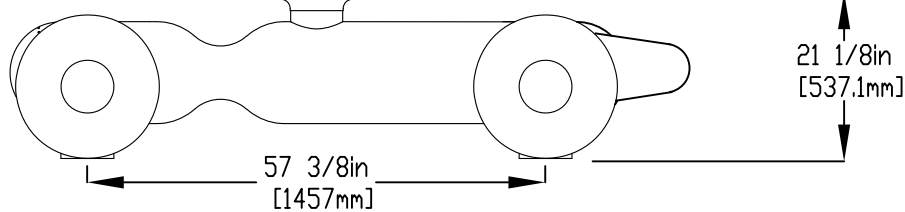

D

D

- (1) BOLT INSERT SLEEVE TO SLAB
- (2) MAKE PLUMBING CONNECTION
- (3) LOWER TOY AND BOLT TO INSERT

1" (25mm) ø HOSE (SUPPLIED BY EMPEX)

2" (50mm) COUPLING
2" (50mm) - 1" (25mm) REDUCER
1" (25mm) HOSEBARB W/ SS CLAMP TO BE PROVIDED BY CONTRACTOR

1/2" (13mm) x 8" (203MM) 316SS THREADED ROD, FENDER WASHER, LOCK WASHER, & NUT (X4), MINIMUM 6" (152mm) EMBEDMENT, EPOXY SET ANCHOR ADHESIVE (PER LEG) TO BE PROVIDED BY CONTRACTOR

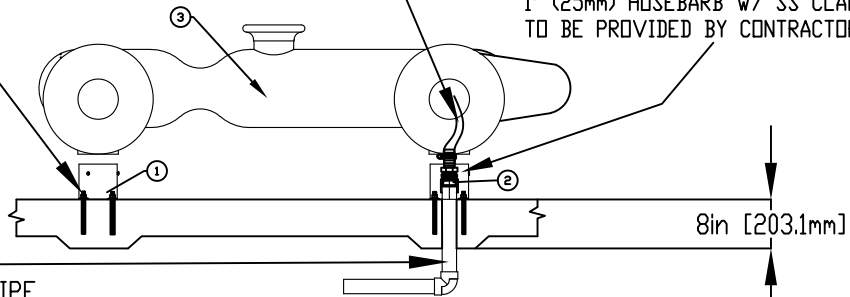

WATERFEED
2" (50mm) PVC SCH40 PIPE
EXTENDED 6" (152mm) ABOVE SLAB

E

E

8in [203.1mm]

F

F



Notes: Overall dimensions of toys are approximate.

© EMPEX WATERTOYS

WATER SUPPLY

30 gpm @ 25 psi
1.89L/S @17.5m

AQUAVROOM

AM102

15/05/2020

SCALE:

Sheet 1 of 1

1

2

3

4