

1

2

3

4

NOTES:

- (1) PURGE ALL WATER SUPPLY LINES TO REMOVE SOLIDS PRIOR TO TOY INSTALLATION.
- (2) PROVIDE ELECTRICAL BOND WITH POOL REBAR.
- (3) INSTALL ALL WATER TOYS PLUMB AND LEVEL.
- (4) PROVIDE STRAINER UPSTREAM OF TOY WITH MAX 1/32" (0.8mm) PERFORATIONS.

A

A

B

B

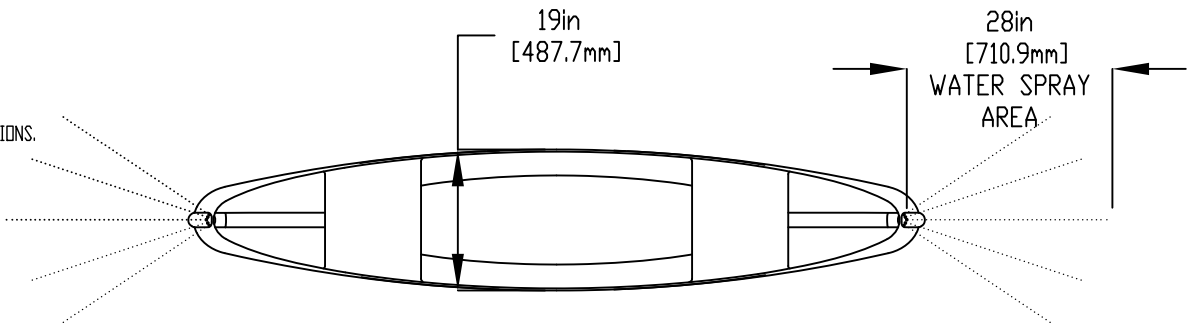

C

C

MAX WATER DEPTH 0" [0mm] - 12" [305mm]

100 1/2in [2546.4mm]

2" (50mm) COUPLING
 2" (50mm) - 1" (25mm) REDUCER
 1" (25mm) HOSE BARB W/ SS CLAMP
 TO BE PROVIDED BY CONTRACTOR

1" (25mm) FLEX HOSE PROVIDED BY EMPEX

17in [427.5mm]

12in [305mm]

8in [203mm]

D

D

1/2" (13mm) X 8" (203mm) 316SS
 THREADED ROD, C/W FENDER WASHER
 LOCK WASHER & NUT (X4) MINIMUM
 6" (152mm) EMBEDMENT EPOXY SET
 ANCHOR ADHESIVE (2SETS)
 TO BE PROVIDED BY CONTRACTOR

WATERFEED
 2" (50mm) SCH 40 PIPE
 EXTEND 6" (152mm) ABOVE SLAB

ø3/4in [Ø19.1mm]

4 1/2in [113.1mm]

E

E

4 1/2in [113.1mm]

BASE ANCHOR DETAIL

F

F



Notes: Overall dimensions of toys are approximate.

© EMPEX WATERTOYS

WATER SUPPLY

30 gpm @ 25 psi
 1.89L/S @17.5m

AQUANDE

AM111

15/05/2020

SCALE:

Sheet 1 of 1

1

2

3

4