

1

2

3

4

NOTES:

(1) PURGE ALL WATER SUPPLY LINES TO REMOVE SOLIDS PRIOR TO TOY INSTALLATION.

(2) PROVIDE ELECTRICAL BOND WITH POOL REBAR.

(3) INSTALL ALL WATER TOYS PLUMB AND LEVEL.

(4) PROVIDE STRAINER UPSTREAM OF TOY WITH MAX 1/32" (0.8mm) PERFORATIONS.

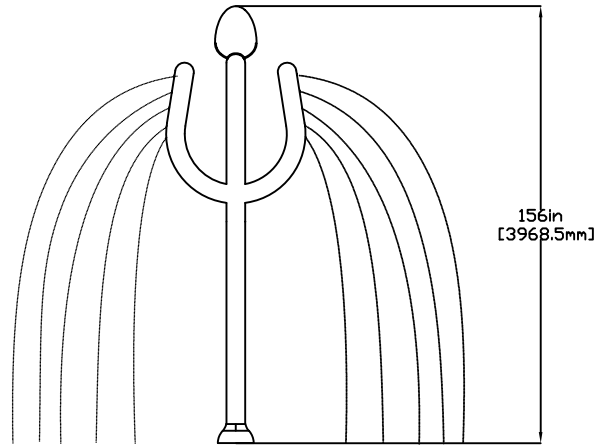
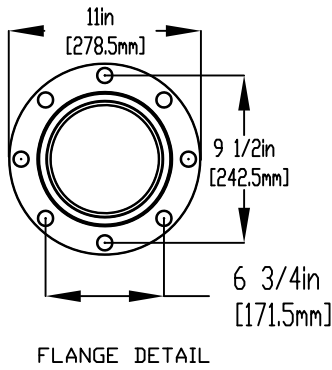
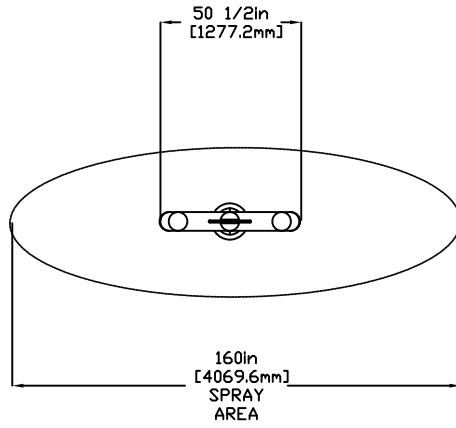

1/2" (13mm) X 8" (203mm) 316SS  
 THREADED ROD, C/W FENDER WASHER,  
 LOCK WASHER & NUT (X6) MINIMUM  
 6" (152mm) EMBEDMENT, EPOXY SET  
 ANCHOR ADHESIVE  
 TO BE PROVIDED BY CONTRACTOR

LOWER FLANGE  
 COVERS AFTER TOY  
 IS INSTALLED

FLOODED COLUMN  
 ENSURE LEVEL & PLUMB  
 4" (101mm) (6" 152mm) X 1/8" (3mm)  
 GASKET, INSTALLED UNDER FLANGE  
 TO BE PROVIDED BY EMPEX

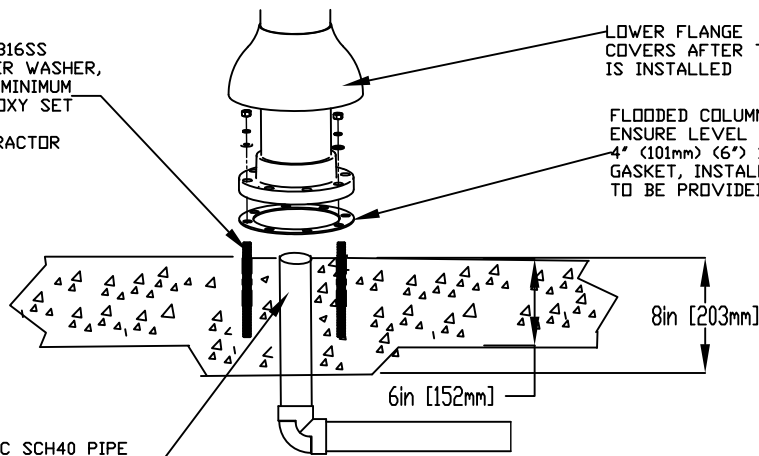

WATERFEED  
 2" (50MM) PVC SCH40 PIPE  
 CUT CLOSE PRIOR TO INSTALL  
 TO ALLOW FOR FULL DRAINAGE

Notes: Overall dimensions of toys are approximate.  
 Approximate Weight: 68lbs/30.9kgs per unit

© EMPEX WATERTOYS



WATER SUPPLY PER UNIT  
 30 gpm @ 25 psi  
 1.89L/S @17.5m

AQUATRIDENT

M514

06/06/2023

SCALE:

Sheet  
1 of 1

1

2

3

4