

NOTES:

- (1) PURGE ALL WATER SUPPLY LINES TO REMOVE SOLIDS PRIOR TO TOY INSTALLATION.
- (2) PROVIDE ELECTRICAL BOND WITH POOL REBAR.
- (3) INSTALL ALL WATER TOYS PLUMB AND LEVEL.
- (4) PROVIDE STRAINER UPSTREAM OF TOY WITH MAX 1/32" (0.8mm) PERFORATIONS.

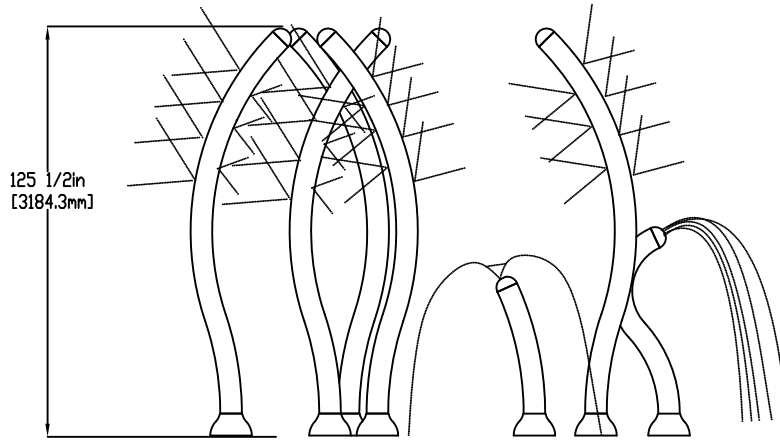
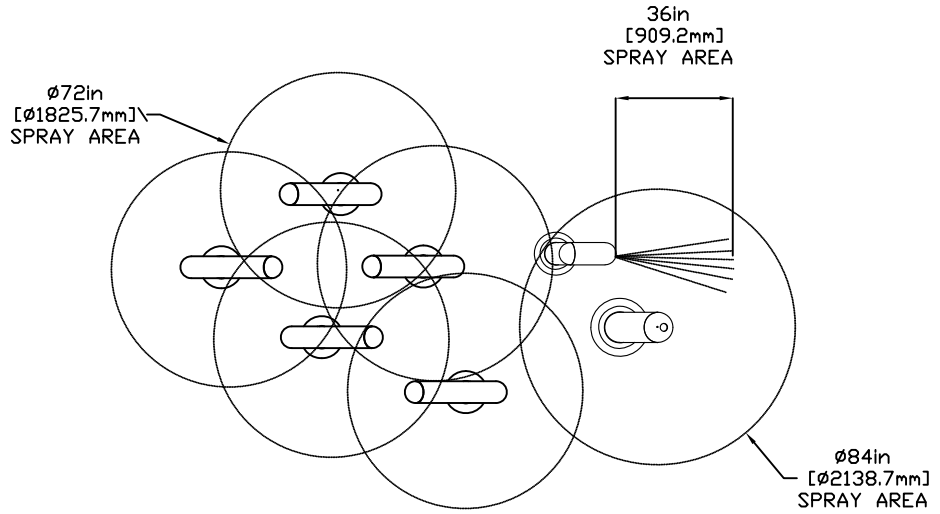

1/2" (13mm) X 8" (203mm) 316SS
 THREADED ROD, C/W FENDER WASHER,
 LOCK WASHER & NUT (X6) MINIMUM
 6" (152mm) EMBEDMENT, EPOXY SET
 ANCHOR ADHESIVE
 TO BE PROVIDED BY CONTRACTOR

LOWER FLANGE
 COVERS AFTER TOY
 IS INSTALLED

FLOODED COLUMN
 ENSURE LEVEL & PLUMB
 (6") 152mm) X 1/8" (3mm)
 GASKET, INSTALLED UNDER FLANGE
 TO BE PROVIDED BY EMPEX

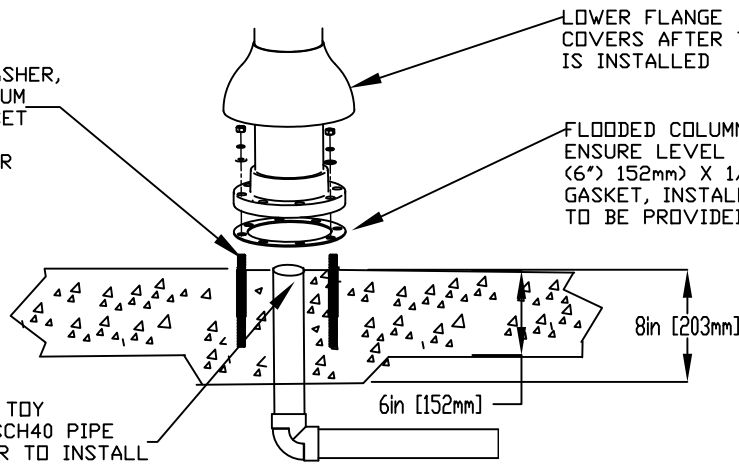

WATERFEED PER TOY
 2" (50MM) PVC SCH40 PIPE
 CUT CLOSE PRIOR TO INSTALL
 TO ALLOW FOR FULL DRAINAGE

Notes: Overall dimensions of toys are approximate.
 Approximate Total Weight: 410Lbs/186kgs

© EMPEX WATERTOYS



WATER SUPPLY PER UNIT

30 gpm @ 25 psi
 1.89L/S @17.5m

AQUACLUSTER

M518

31/01/2024

SCALE:

Sheet
 1 of 1