

1

2

3

4

NOTES:

- (1) PURGE ALL WATER SUPPLY LINES TO REMOVE SOLIDS PRIOR TO TOY INSTALLATION.
- (2) PROVIDE ELECTRICAL BOND WITH POOL REBAR.
- (3) INSTALL ALL WATER TOYS PLUMB AND LEVEL.
- (4) PROVIDE STRAINER UPSTREAM OF TOY WITH MAX 1/32" (0.8mm) PERFORATIONS.

A

A

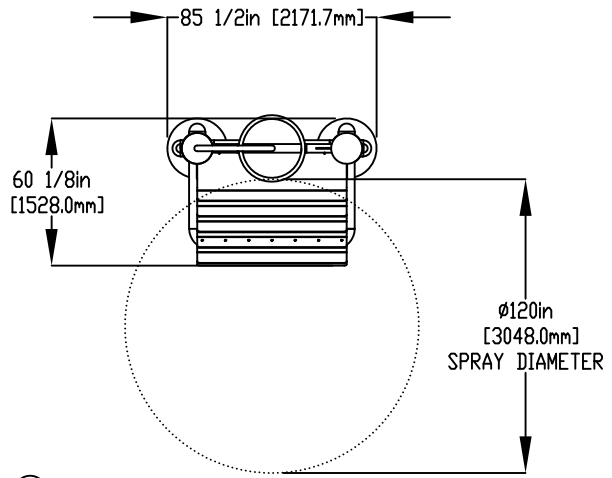

B

B

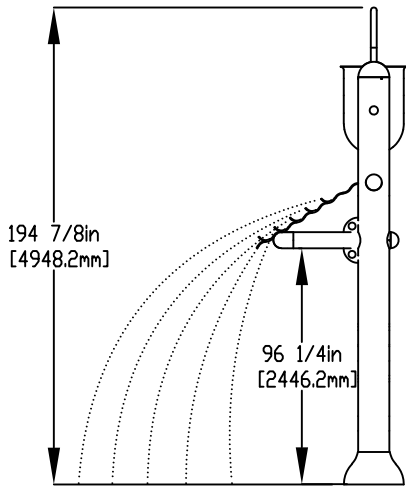

C

C

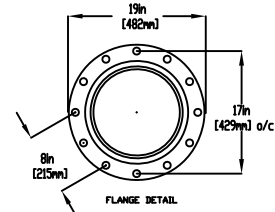
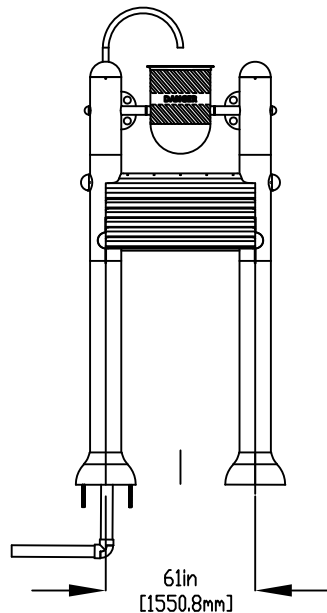

D

D

5/8" (16mm) X 9" (229mm) 316 SS THREADED ROD, C/W FENDER WASHER LOCK WASHER & NUT (X6) MINIMUM 6" EMBEDMENT, EPOXY SET ANCHOR ADHESIVE (EACH LEG) TO BE PROVIDED BY CONTRACTOR

LOWER FLANGE COVERS AFTER TOY IS INSTALLED

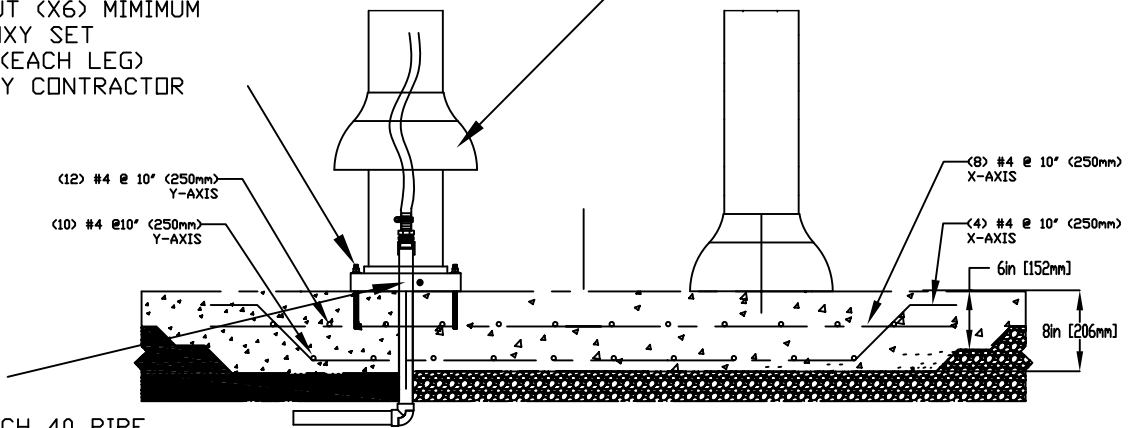

E

E

WATERFEED
2" (50mm) PVC SCH 40 PIPE
EXTENDED 6" (152mm) ABOVE SLAB.

F

F



Notes: Overall dimensions of toys are approximate.
Approximate Weight: 540lbs / 245.5kgs

© EMPEX WATERTOYS

WATER SUPPLY
70 gpm @ 25 psi
4.4 L/S @17.5m

AQUADUNKER

ABU024

01/03/2021

SCALE:

Sheet
1 of 1

1

2

3

4