

1

2

3

4

NOTES:

- (1) PURGE ALL WATER SUPPLY LINES TO REMOVE SOLIDS PRIOR TO TOY INSTALLATION.
- (2) PROVIDE ELECTRICAL BOND WITH POOL REBAR.
- (3) INSTALL ALL WATER TOYS PLUMB AND LEVEL.
- (4) PROVIDE STRAINER UPSTREAM OF TOY WITH MAX 1/32" (0.8mm) PERFORATIONS.

A

A

B

B

C

C

D

D

E

E

F

F

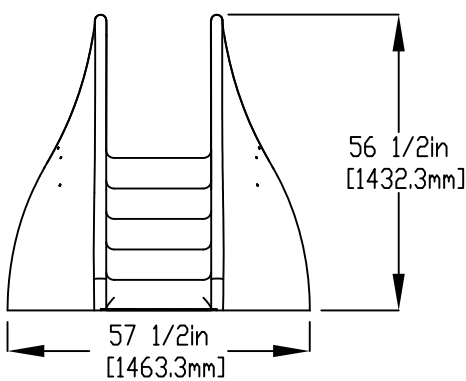
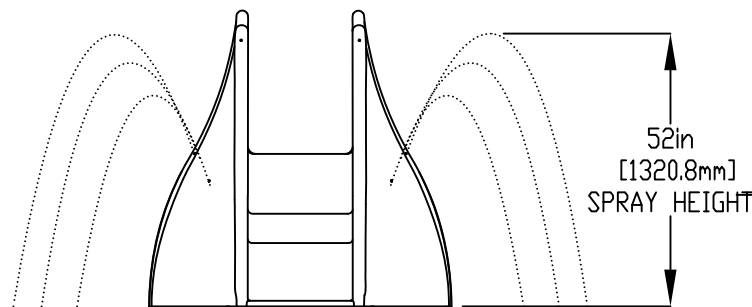
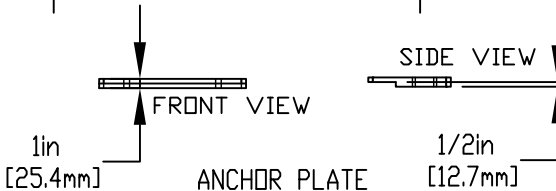
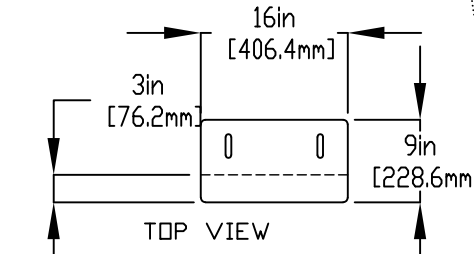
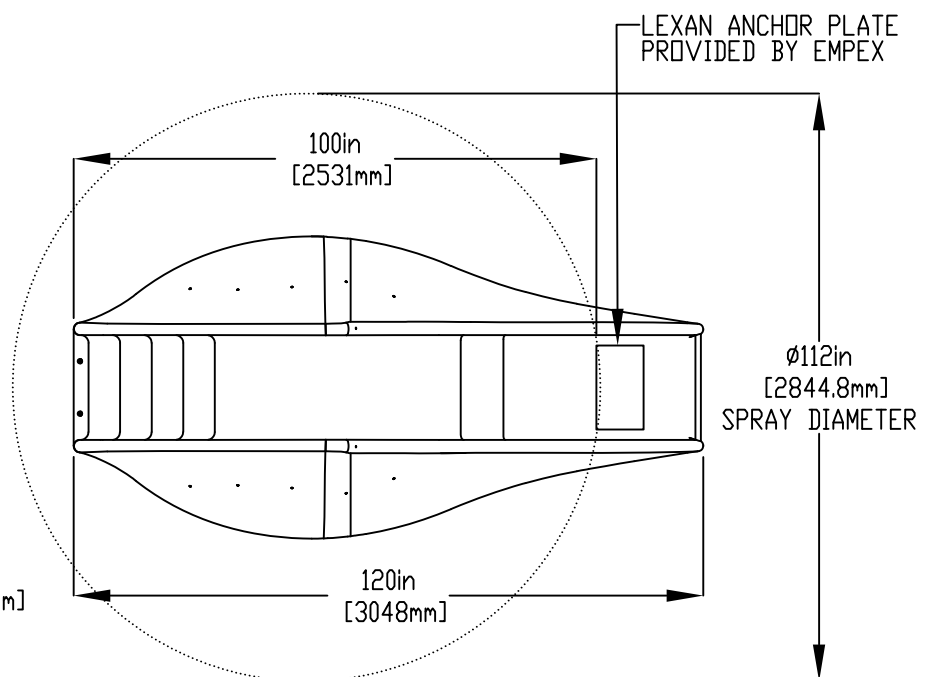

2" (50mm) COUPLING  
 2" (50mm) TO 1" (25mm) REDUCER  
 1" (25mm) HOSEBARB W/ SS CLAMP  
 TO BE PROVIDED BY CONTRACTOR

1/2" (13mm) X 1-1/2" (38mm) 316SS  
 COUNTER SINK SCREWS COMPLETE  
 WITH 2" FEMALE ANCHOR, 2" (38mm)  
 EMBEDMENT (PROVIDED BY EMPEX),  
 EPOXY SET ANCHOR ADHESIVE

WATERFEED  
 2" (50mm) SCH 40 PVC PIPE  
 EXTENDED 6" (152mm) ABOVE SLAB.

1" (25mm) FLEX HOSE  
 PROVIDED BY EMPEX

1/2" (13mm) X 8" (203mm) 316SS  
 THREADED ROD C/W FENDER WASHER,  
 LOCK WASHER & NUT (x2) MINIMUM  
 6" (152mm) EMBEDMENT, EPOXY SET  
 ANCHOR ADHESIVE  
 TO BE PROVIDED BY CONTRACTOR

MAX  
 WATER DEPTH  
 0in - 12in  
 [305.2mm]

8in [203.2mm]

Notes: Overall dimensions of toys are approximate.  
 Approximate Weight: 156lbs / 70.9kgs

© EMPEX WATERTOYS



WATER SUPPLY  
 30 gpm @ 20 psi  
 1.89 L/S @14.5m

AQUAWAVE DOLCE

AD450	1/20/2020	SCALE:	Sheet 1 of 1
-------	-----------	--------	-----------------

1

2

3

4