

A  
B  
C  
D  
E  
F

A  
B  
C  
D  
E  
F

**NOTES:**

- (1) PURGE ALL WATER SUPPLY LINES TO REMOVE SOLIDS PRIOR TO TOY INSTALLATION.
- (2) PROVIDE ELECTRICAL BOND WITH POOL REBAR.
- (3) INSTALL ALL WATER TOYS PLUMB AND LEVEL.
- (4) PROVIDE STRAINER UPSTREAM OF TOY WITH MAX 1/32" (0.8mm) PERFORATIONS.

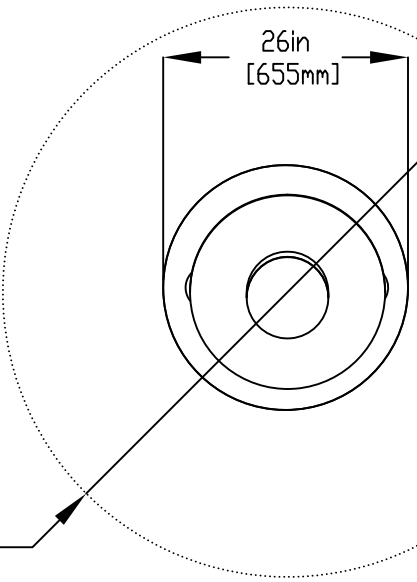

Ø60in [Ø1524.0mm]  
SPRAY DIAMETER NTS

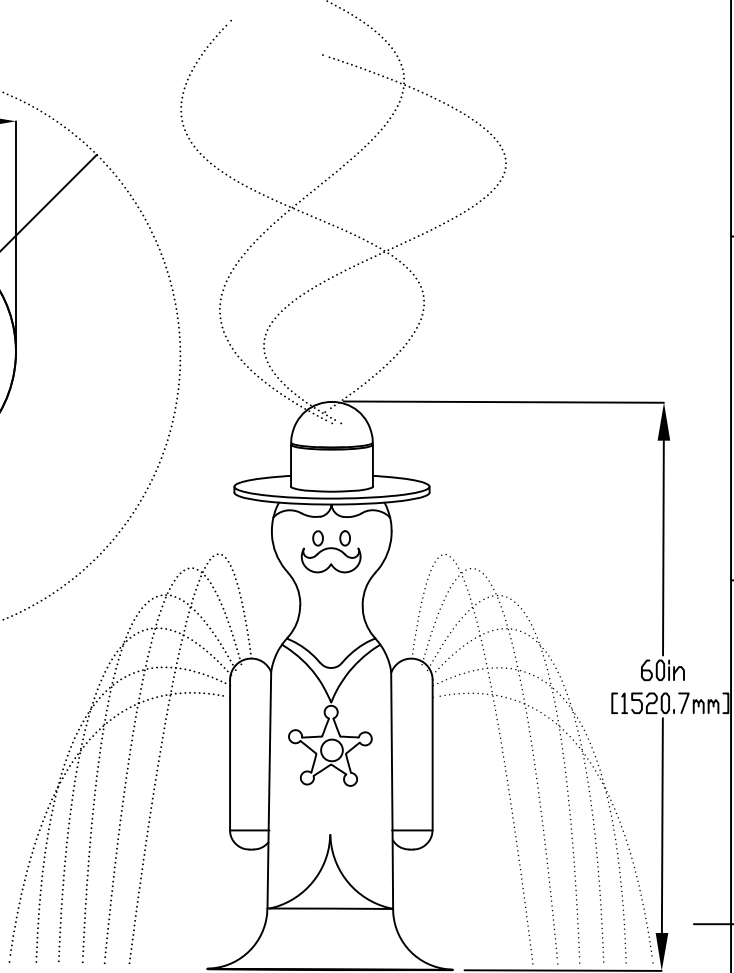
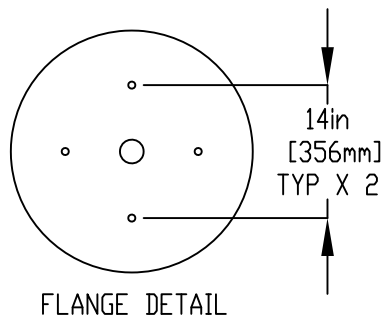

Push Diverter

1" (25mm) FLEX HOSE PROVIDED BY EMPEX.

2" (50mm) COUPLING  
2" (50mm) - 1" (25mm) REDUCER  
1" (25mm) HOSEBARB W/SS CLAMP TO BE PROVIDED BY CONTRACTOR

LOWER FLANGE COVER AFTER TOY IS INSTALLED.

1/2" (13mm) X 8" (203mm) 316SS THREADED ROD C/W FENDER WASHER LOCKWASHER & NUT (X4) MINIMUM 6" (152mm) EMBEDMENT, EPOXY SET ANCHOR ADHESIVE TO BE PROVIDED BY CONTRACTOR

WATER FEED.  
2" (50mm) PVC SCH40 PIPE EXTENDED 6" (152mm) ABOVE PAD

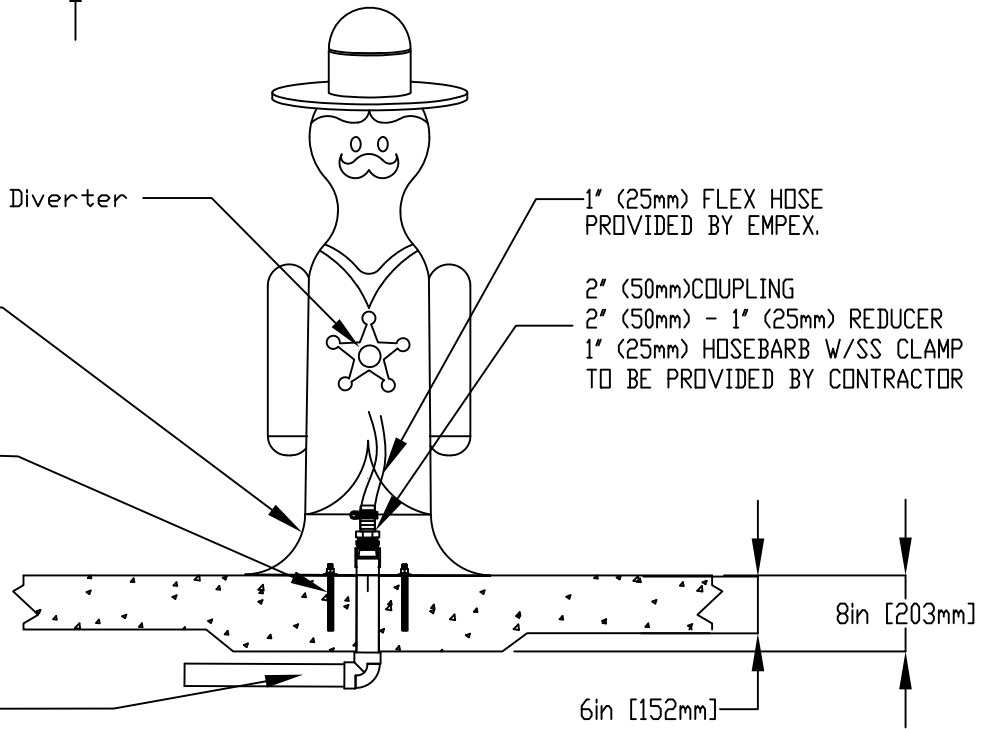

Notes: Overall dimensions of toys are approximate.

© EMPEX WATERTOYS

WATER SUPPLY  
30 gpm @ 25 psi  
1.89L/S @17.5m

AQUATOT SHERIFF

AT111

01/04/2020

SCALE:

Sheet 1 of 1