

NOTES:

- (1) PURGE ALL WATER SUPPLY LINES TO REMOVE SOLIDS PRIOR TO TOY INSTALLATION.
- (2) PROVIDE ELECTRICAL BOND WITH POOL REBAR.
- (3) INSTALL ALL WATER TOYS PLUMB AND LEVEL.
- (4) PROVIDE STRAINER UPSTREAM OF TOY WITH MAX 1/32" (0.8mm) PERFORATIONS.

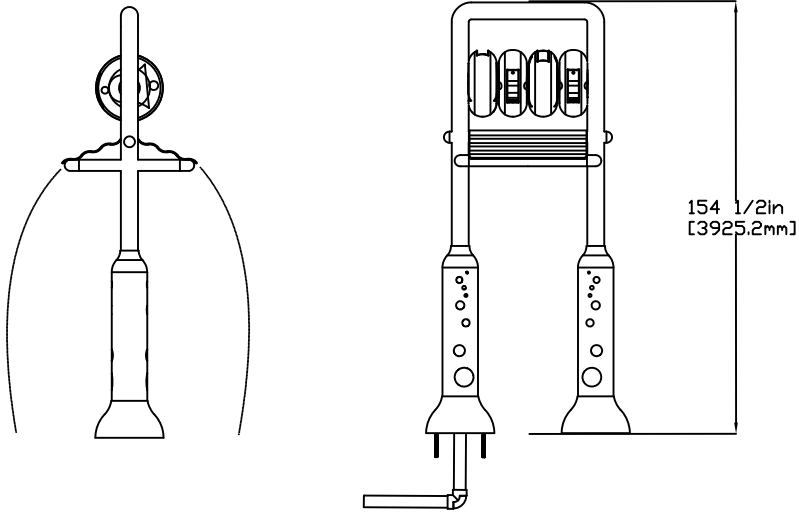
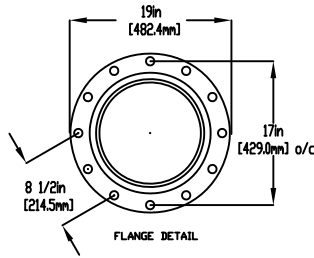
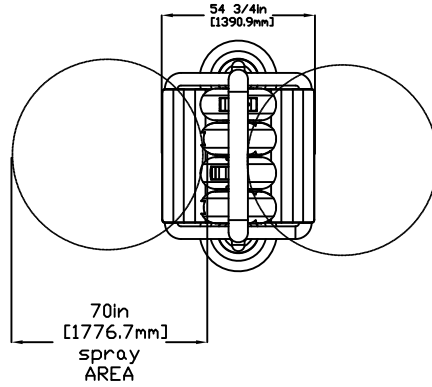

1" (25mm) FLEX HOSE PROVIDED BY EMPEX

2" (50mm) COUPLING
 2" (50mm) TO 1" (25mm) REDUCER
 1" (25mm) HOSE BARB W/SS CLAMP TO BE PROVIDED BY CONTRACTOR

5/8" (16mm) X 9" (229mm) 316 SS THREADED ROD, C/W FENDER WASHER LOCK WASHER & NUT (X6) MINIMUM 6" EMBEDMENT, EPOXY SET ANCHOR ADHESIVE (EACH LEG) TO BE PROVIDED BY CONTRACTOR

LOWER FLANGE COVERS AFTER TOY IS INSTALLED

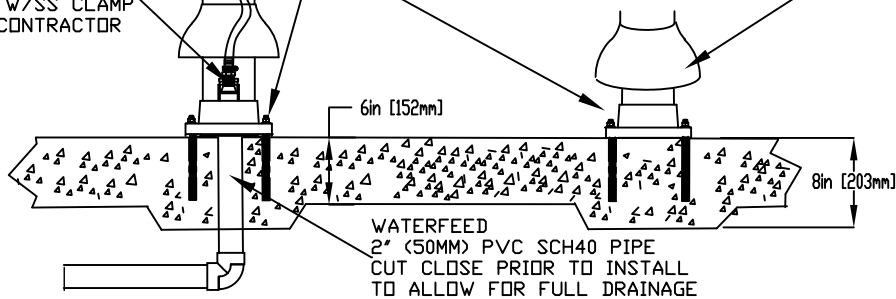

Notes: Overall dimensions of toys are approximate.
 Approximate Weight: 68lbs/30.9kgs per unit

© EMPEX WATERTOYS



WATER SUPPLY PER UNIT
 40 gpm @ 25 psi
 2.52L/S @17.5m

AQUATUMBLE

M520

08/02/2024

SCALE:

Sheet
 1 of 1