

NOTES:

- (1) PURGE ALL WATER SUPPLY LINES TO REMOVE SOLIDS PRIOR TO TOY INSTALLATION.
- (2) PROVIDE ELECTRICAL BOND WITH POOL REBAR.
- (3) INSTALL ALL WATER TOYS PLUMB AND LEVEL.
- (4) PROVIDE STRAINER UPSTREAM OF TOY WITH MAX 1/32" (0.8mm) PERFORATIONS.

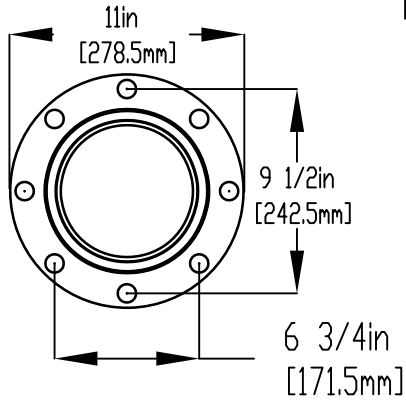

FLANGE DETAIL

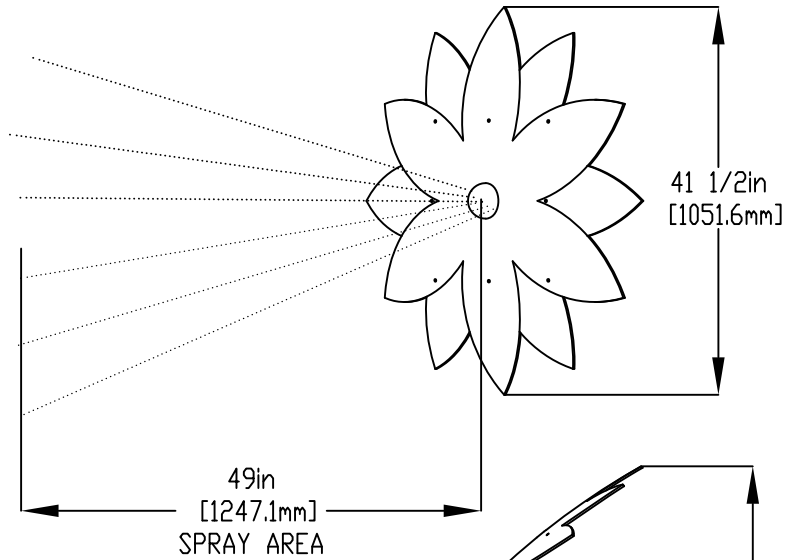
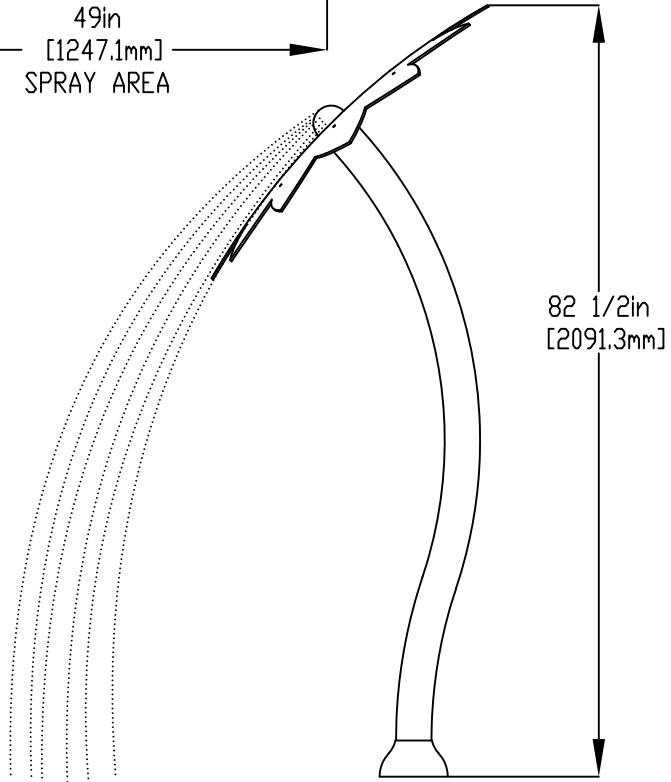

LOWER FLANGE COVERS AFTER TOY IS INSTALLED

1" (25mm) FLEX HOSE PROVIDED BY EMPEX

1/2" (13mm) X 8" (203mm) 316SS THREADED ROD, C/W FENDER WASHER, LOCK WASHER & NUT (X6) MINIMUM 6" (152mm) EMBEDMENT, EPOXY SET ANCHOR ADHESIVE TO BE PROVIDED BY CONTRACTOR

2" (50mm) COUPLING
2" (50mm) TO 1" (25mm) REDUCER
1" (25mm) HOSE BARB W/SS CLAMP TO BE PROVIDED BY CONTRACTOR

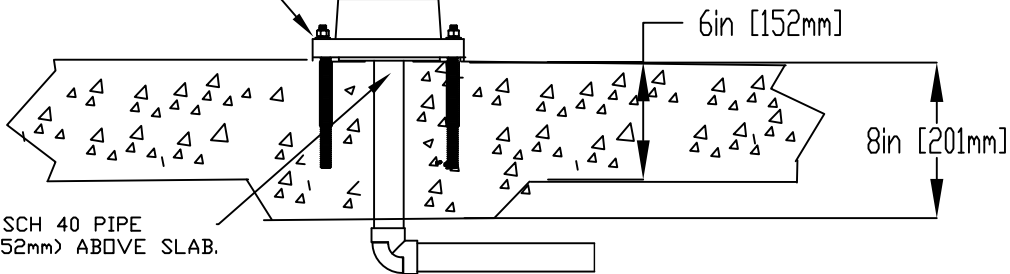

WATERFEED
2" (50mm) PVC SCH 40 PIPE EXTENDED 6" (152mm) ABOVE SLAB.

Notes: Overall dimensions of toys are approximate.

© EMPEX WATERTOYS



WATER SUPPLY
30 gpm @ 25 psi
1.89L/S @17.5m

AQUABISCUS

TR875

07/02/2024

Sheet 1 of 1