

1

2

3

4

A

A

NOTES:

- (1) PURGE ALL WATER SUPPLY LINES TO REMOVE SOLIDS PRIOR TO TOY INSTALLATION.
- (2) PROVIDE ELECTRICAL BOND WITH POOL REBAR.
- (3) INSTALL ALL WATER TOYS PLUMB AND LEVEL.
- (4) PROVIDE STRAINER UPSTREAM OF TOY WITH MAX 1/32" (0.8mm) PERFORATIONS.

72in
[1828.8mm]
SPRAY AREA

34 1/2in
[881.9mm]

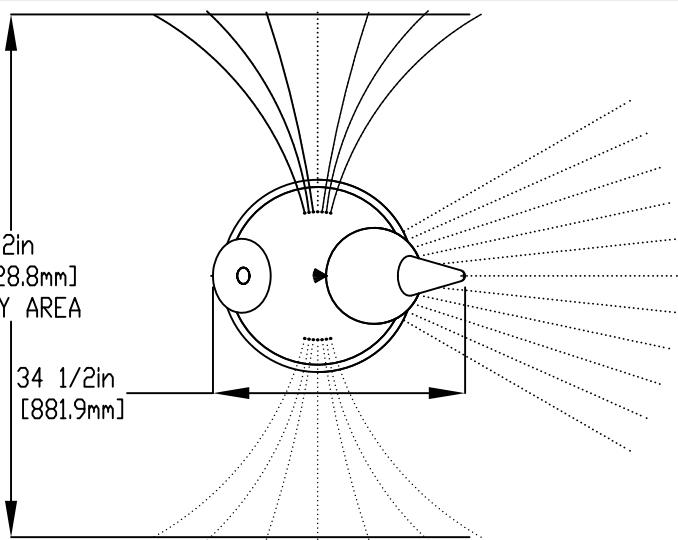

B

B

C

C

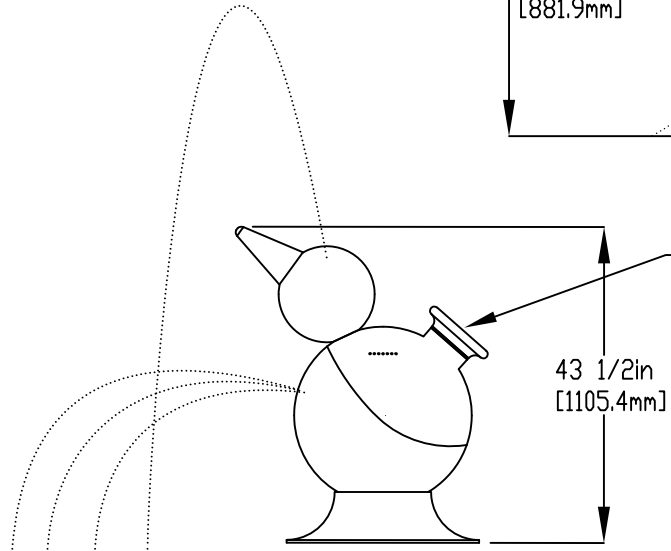

2-WAY
DIVERTER

43 1/2in
[1105.4mm]

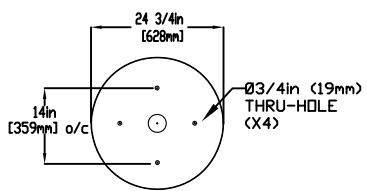

MOUNTING BOLT PATTERN

D

D

1. BOLT BASE MOUNTING PLATE
2. MAKE PLUMBING CONNECTIONS
3. LOWER TOY AND ATTACH TO BOTTOM

1/2" (13mm) X 8" (203mm) 316SS
THREADED ROD, C/W FENDER WASHER,
LOCK WASHER & NUT (X6) MINIMUM
6" (152mm) EMBEDMENT, EPOXY SET
ANCHOR ADHESIVE
TO BE PROVIDED BY CONTRACTOR

1" (25mm) FLEX HOSE
PROVIDED BY EMPEX

2" (50mm) COUPLING
2" (50mm) TO 1-1/2" (38mm REDUCER)
1-1/2" (38mm) HOSEBARB W/SS CLAMP
TO BE PROVIDED BY CONTRACTOR

8in [203mm]

6in [152mm]

WATERFEED
2" (50mm) PVC SCH 40 PIPE
EXTENDED 6" (152mm) ABOVE SLAB.

E

E

F

F



Notes: Overall dimensions of toys are approximate.

© EMPEX WATERTOYS

WATER SUPPLY
30 gpm @ 25 psi
1.89L/S @17.5m

AQUATWEET W DIVERTER

TR962-D

02/02/2024

SCALE:

Sheet
1 of 1

1

2

3

4