

A

A

B

B

C

C

D

D

E

E

F

F

NOTES:

- (1) PURGE ALL WATER SUPPLY LINES TO REMOVE SOLIDS PRIOR TO TOY INSTALLATION.
- (2) PROVIDE ELECTRICAL BOND WITH POOL REBAR.
- (3) INSTALL ALL WATER TOYS PLUMB AND LEVEL.
- (4) PROVIDE STRAINER UPSTREAM OF TOY WITH MAX 1/32" (0.8mm) PERFORATIONS.

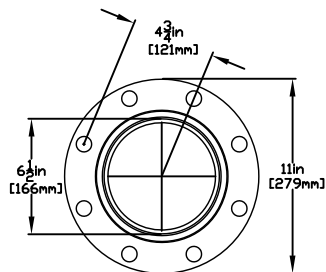
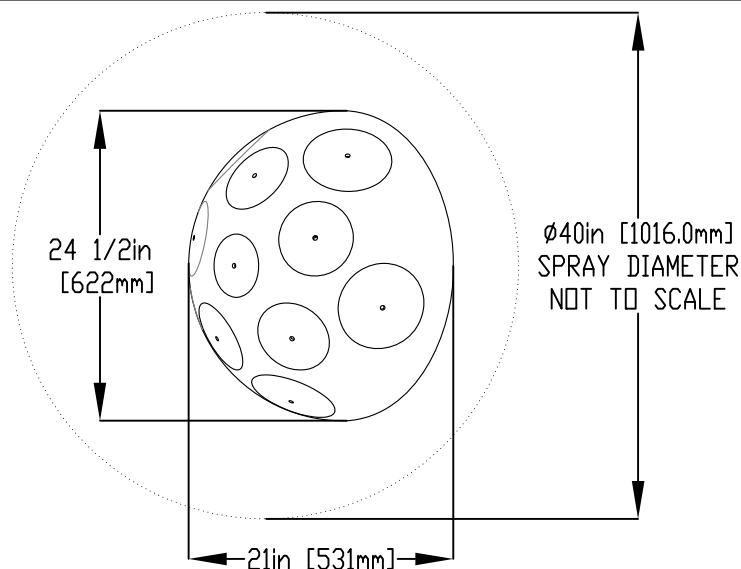

FLANGE DETAIL

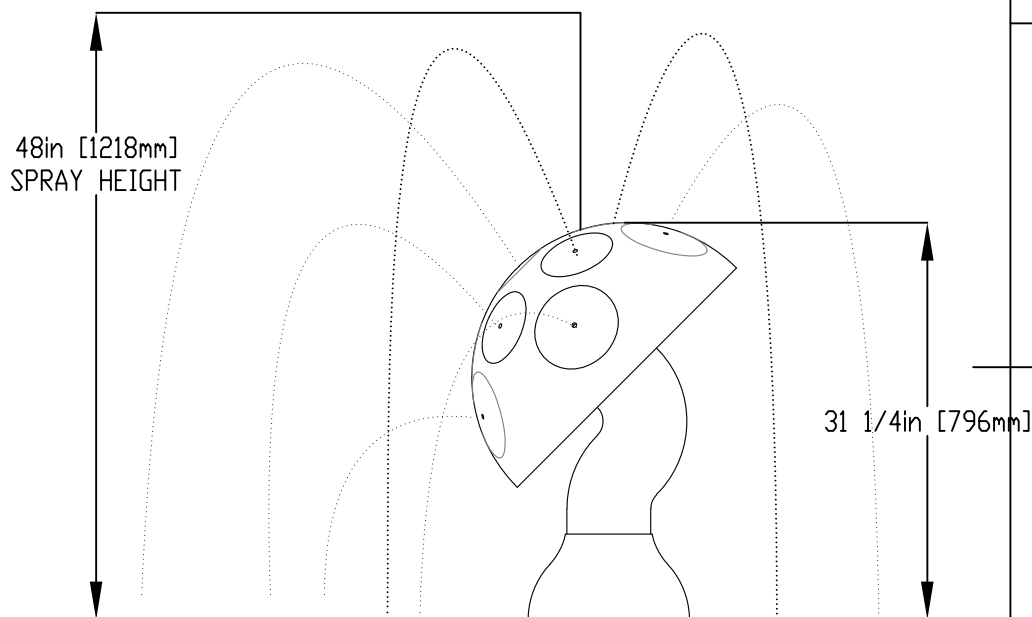

LOWER COVER AFTER INSTALL.

1/2" (13mm) X 7" (180mm) 316SS THREADED ROD, C/W FENDER WASHER, LOCK WASHER & NUT (X4). MINIMUM 6" (152mm) EMBEDMENT, EPOXY SET ANCHOR ADHESIVE TO BE PROVIDED BY CONTRACTOR

1" (25mm) FLEX HOSE PROVIDED BY EMPEX.

2" (50mm) COUPLING, 2" (50mm) TO 1" (25mm), 1" (25mm) HOSEBARB FITTING AND 1" (25mm) SS CLAMP, TO BE SUPPLIED BY CONTRACTOR

WATERFEED 2" (50mm) PVC SCH 40 PIPE EXTENDED 6" (152mm) ABOVE SLAB.

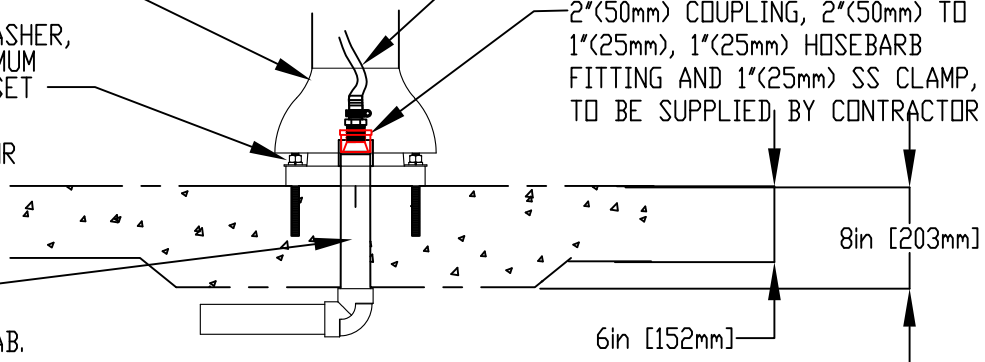

Notes: Overall dimensions of toys are approximate.

© EMPEX WATERTOYS

WATER SUPPLY
20 gpm @ 25 psi
1.3L/S @17.5m

AQUACAP

TR269S

10/31/2019

SCALE:

Sheet 1 of 1